

PRINTER/SCANNER CONTROLLERS
(Machine Code: B463/B529)
SERVICE MANUAL

TABLE OF CONTENTS

1. INSTALLATION.....	1-1
1.1 INSTALLATION REQUIREMENTS.....	1-1
1.2 PRINTER/SCANNER INSTALLATION	1-1
Accessory Check	1-1
Printer, Printer/Scanner Controller Installation	1-2
1.3 PRINTER OPTIONS.....	1-6
1.3.1 POSTSCRIPT UNIT (B522)	1-6
1.3.2 IEEE1394 INTERFACE (G539)	1-7
1.3.3 WIRELESS LAN (B515).....	1-8
1.4 CHECKING THE CONNECTIONS	1-10
2. TROUBLESHOOTING.....	2-1
2.1 CONTROLLER ERRORS.....	2-1
2.2 LEDS AND TEST POINTS	2-1
3. SERVICE TABLES.....	3-1
3.1 SERVICE PROGRAM MODE.....	3-1
3.1.1 ENABLING AND DISABLING SERVICE PROGRAM MODE	3-1
Entering the SP mode	3-1
Exiting the Service Mode	3-1
3.2 PRINTER SERVICE MODE.....	3-2
3.2.1 SERVICE MODE TABLE	3-2
Service Table Key	3-2
3.2.2 SP MODES RELATED TO THE PRINTER CONTROLLER	3-4
3.3 SCANNER SERVICE MODE.....	3-5
3.3.1 SCANNER PROGRAM MODE TABLE	3-5
SP1-XXX (System and Others).....	3-5
SP2-XXX (Scanning-image quality)	3-6
3.4 FIRMWARE UPDATE PROCEDURE	3-17
3.5 POWER-ON SELF TEST.....	3-17
3.6 SELF DIAGNOSTIC TEST	3-17
3.7 USER PROGRAM MODE.....	3-18
3.7.1 PRINTER USER PROGRAM MODE	3-18
4. DETAILED SECTION DESCRIPTIONS.....	4-1
4.1 OVERVIEW	4-1
4.2 PRINT DATA PROCESSING.....	4-2
4.2.1 RPCS DRIVER	4-2
4.2.2 PCL5C DRIVER.....	4-2
4.2.3 PS3 DRIVER.....	4-3
CMS (Color Management System)	4-3
Gray Correction.....	4-3
BG/UCR (Black Generation/Under Color Removal)	4-3
Gamma Correction.....	4-3
Toner Limitation	4-4

Dither Processing and ROP/RIP	4-4
4.3 CONTROLLER FUNCTIONS	4-5
4.3.1 SAMPLE PRINT.....	4-5
4.3.2 LOCKED PRINT	4-5
4.3.3 JOB SPOOLING	4-5
Related SP Modes	4-5
4.3.4 PAPER SOURCE SELECTION	4-6
Tray Priority (Auto Tray Select)	4-6
Tray Lock	4-6
Manual Tray Select	4-6
4.3.5 AUTO CONTINUE	4-7
4.3.6 PAPER OUTPUT TRAY	4-8
Output Tray Selected	4-8
4.3.7 DUPLEX PRINTING	4-8
4.3.8 STAPLING	4-9
4.4 NIB.....	4-10
4.4.1 BLOCK DIAGRAM	4-10
4.4.2 LED INDICATORS.....	4-10
4.5 IEEE1394 INTERFACE	4-11
4.5.1 SPECIFICATIONS	4-11
Hardware Specification	4-11
System Requirements.....	4-11
4.5.2 IEEE1394.....	4-11
4.5.3 BLOCK DIAGRAM	4-12
4.5.4 PIN ASSIGNMENT	4-12
4.5.5 REMARKS ABOUT THIS INTERFACE KIT	4-13
4.5.6 TROUBLESHOOTING NOTES.....	4-13
4.5.7 IP OVER IEEE1394	4-14
4.6 IEEE802.11B (WIRELESS LAN)	4-15
4.6.1 SPECIFICATIONS	4-15
4.6.2 BLOCK DIAGRAM.....	4-15
4.6.3 TRANSMISSION MODE	4-16
Ad hoc Mode.....	4-16
Infrastructure Mode	4-16
4.6.4 SECURITY FEATURES.....	4-17
Using the SSID in Ad hoc mode.....	4-17
4.6.5 TROUBLESHOOTING NOTES.....	4-18
Communication Status	4-18
Channel Settings.....	4-18
Troubleshooting Steps	4-19
4.7 SCANNER FUNCTIONS	4-20
4.7.1 IMAGE PROCESSING FOR SCANNER MODE	4-20
Image Data Path	4-20

SPECIFICATIONS.....	Spec-1
1. GENERAL SPECIFICATIONS.....	Spec-1
1.1 PRINTER	Spec-1
Supported Paper Sizes	Spec-2
Paper Feed	Spec-2

Paper Output.....	Spec-3
1.2 SCANNER	Spec-4
1.3 SOFTWARE ACCESSORIES.....	Spec-5
Printer Drivers	Spec-5
Printer Utility Software.....	Spec-5
Scanner Driver	Spec-5
Scanner Utilities	Spec-5

1. INSTALLATION

1.1 INSTALLATION REQUIREMENTS

Please refer to section 1 of the main unit service manual.

1.2 PRINTER/SCANNER INSTALLATION

Accessory Check

Check the accessories in the box against the following list:

No.	Description	Q'ty	Note
1	IEEE1284 (Centronics) Board	1	
2	Network Interface Board	1	
3	DIMM – Printer	1	
4	DIMM – NIB/Scanner	1	Scanner firmware is included only in the B529 (printer and scanner) model
5	NVRAM Board	1	
6	Key Top – Printer	1	
7	Key Top – Scanner	1	Included only in the B529 (printer and scanner) model
8	CD ROM – Printer	1	
9	CD ROM – Scanner	1	Included only in the B453 (printer and scanner) model
10	CD ROM – Operation Manual	1	
11	Operating Instructions	1	
12	FCC Label	1	Included only in the USA models.
13	IC Card Cover	1	
14	Ferrite Core	1	
15	Screw – M3x8	2	
16	Screw – M3x6	3	

Printer, Printer/Scanner Controller Installation

⚠ CAUTION
Unplug the main machine power cord before starting the following procedure.

NOTE: When installing this unit, 128 MB or 256 MB memory must be installed.

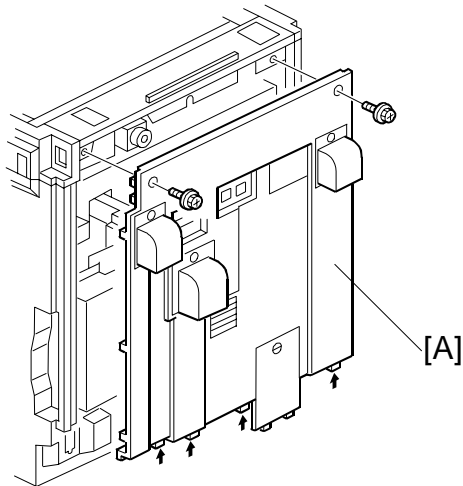

B5291104.WMF

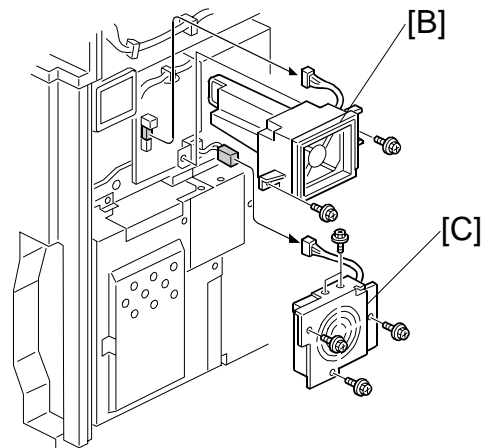

B5291004.WMF

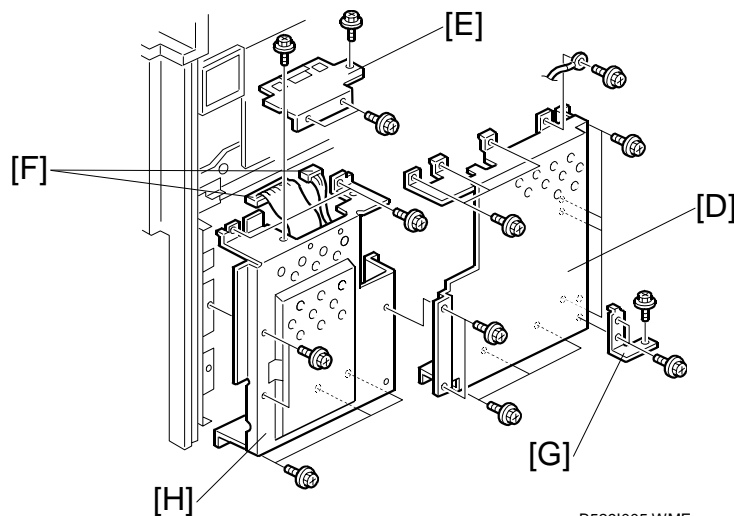

B5291005.WMF

1. Remove the rear cover [A] (⚙ x 2).
2. Remove the cooling fan [B] (⚙ x 2).
3. Remove the PCB fan [C] (⚙ x 3, 🛠 x 1).
4. Remove the BICU cover [D] (⚙ x 16).
5. Remove the HDD connector cover [E] (⚙ x 4).
6. Disconnect two HDD harnesses [F].
7. Remove the bracket [G] (⚙ x 3).
8. Remove the controller board cover [H] (⚙ x 7).

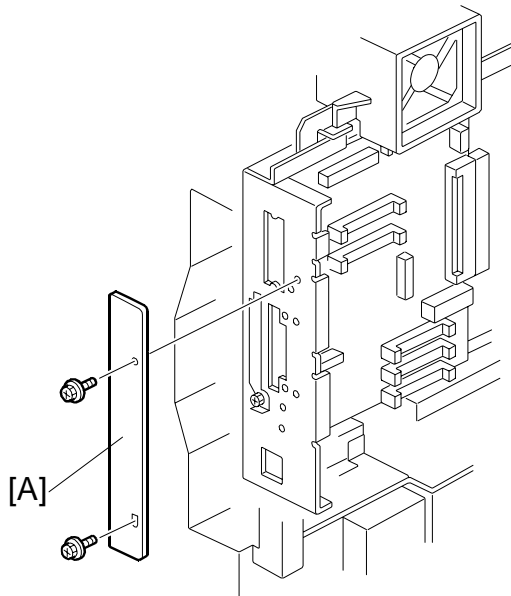

B529I303.WMF

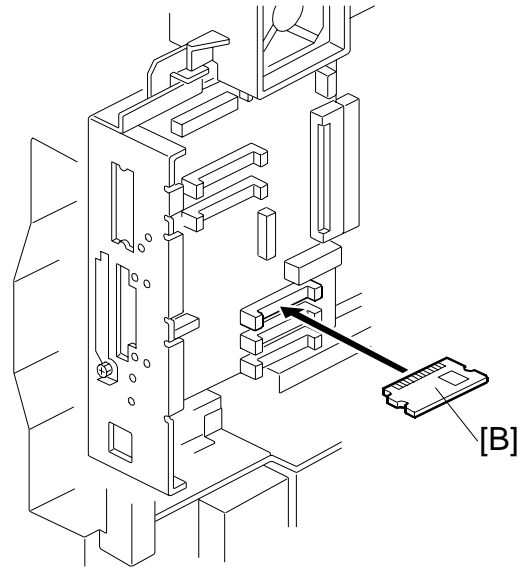

B529I304.WMF

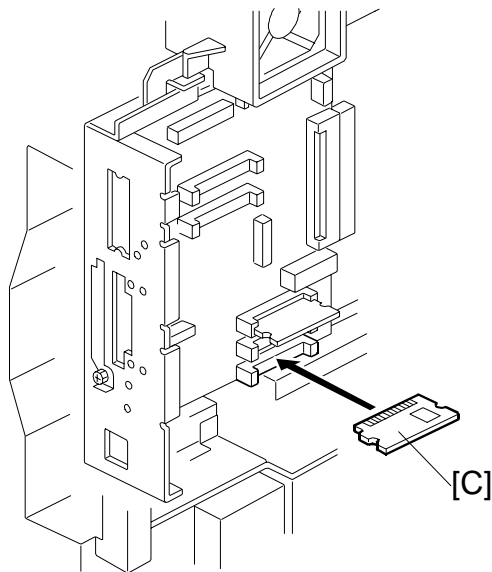

B529I305.WMF

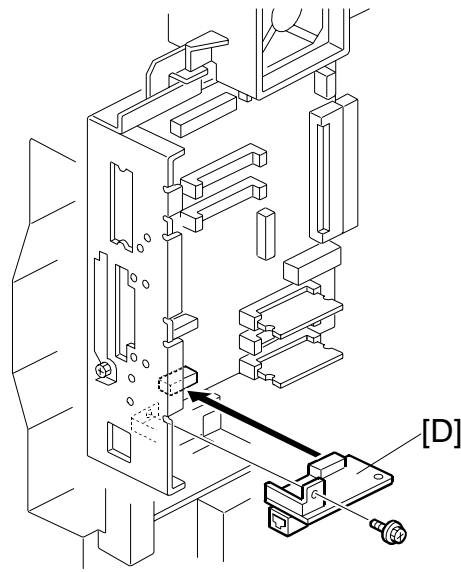

B529I306.WMF

9. Remove the plate [A] ($\times 2$).
10. Install the printer or printer/scanner controller ROM DIMM [B] in Slot 1 on the controller board.
NOTE: The colored label on the DIMM indicates the correct slot. For example, install the DIMM with a blue label in the slot with the blue lock.
11. Install the NIB ROM DIMM [C] in Slot 3 on the controller board.
12. Install the NIB [D] ($\times 1$).

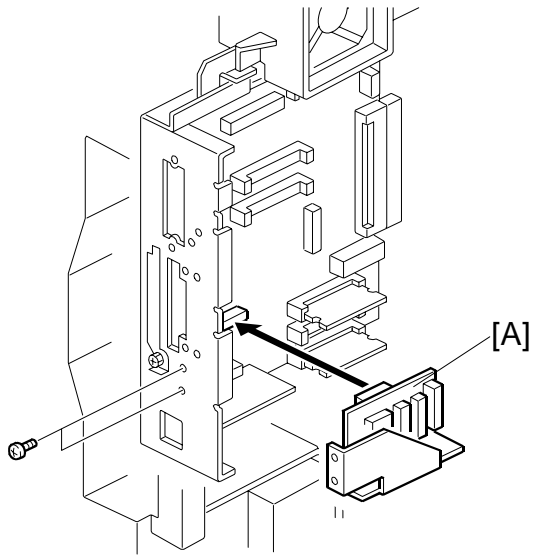

B529I009.WMF

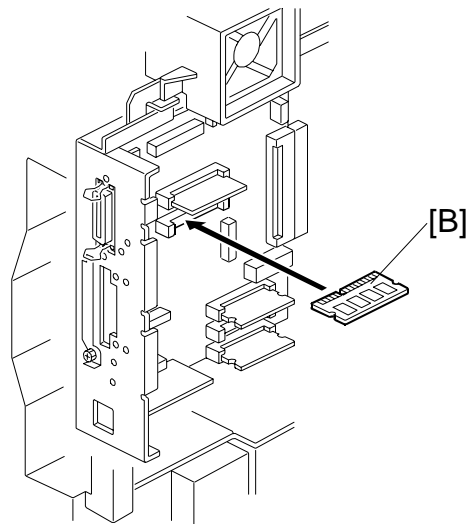

B529I308.WMF

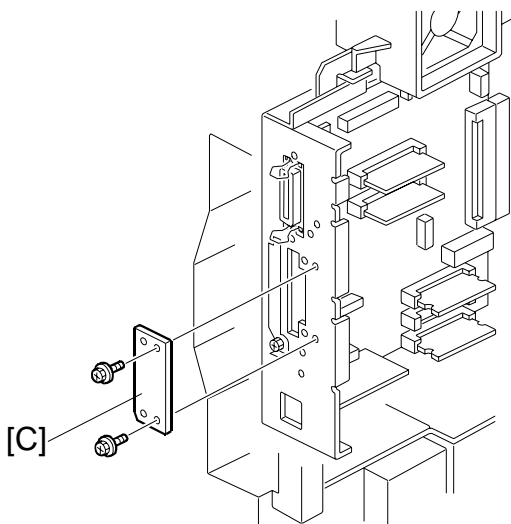

B529I309.WMF

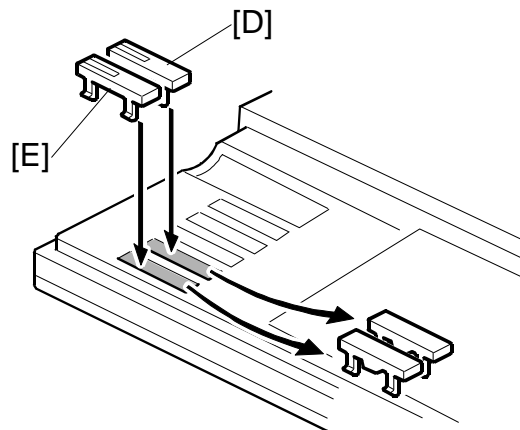

B529I007.WMF

13. Install the NVRAM board [A] (2 x 2).
14. Install the memory [B].
15. If the optional IEEE1394 or wireless LAN will not be installed, install the cover plate [C] (2 x 2).
16. Reassemble the machine.
17. Replace the key tops for the appropriate units to be installed.
 - [D]: Printer
 - [E]: Scanner

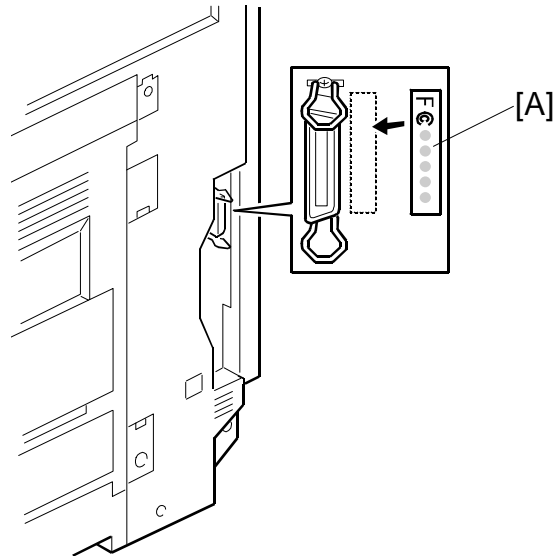

B5291006.WMF

18. Attach the FCC label [A] to the controller panel board as shown.
NOTE: This step is required only in the USA models.
19. Replace the left rear cover.
20. Replace the controller board cover and rear cover.
21. When installing the Printer/Scanner DIMM, perform copier SP5-801-9 (Memory All Clear – Scanner Application).
22. Ensure that the plug and play setting is correct (copier SP 5-907).

1.3 PRINTER OPTIONS

1.3.1 POSTSCRIPT UNIT (B522)

⚠ CAUTION

Unplug the main machine's power cord before starting the following procedure.

NOTE: To install the Postscript option, the printer option (B463 or B529) must be installed first (☛ 1.2).

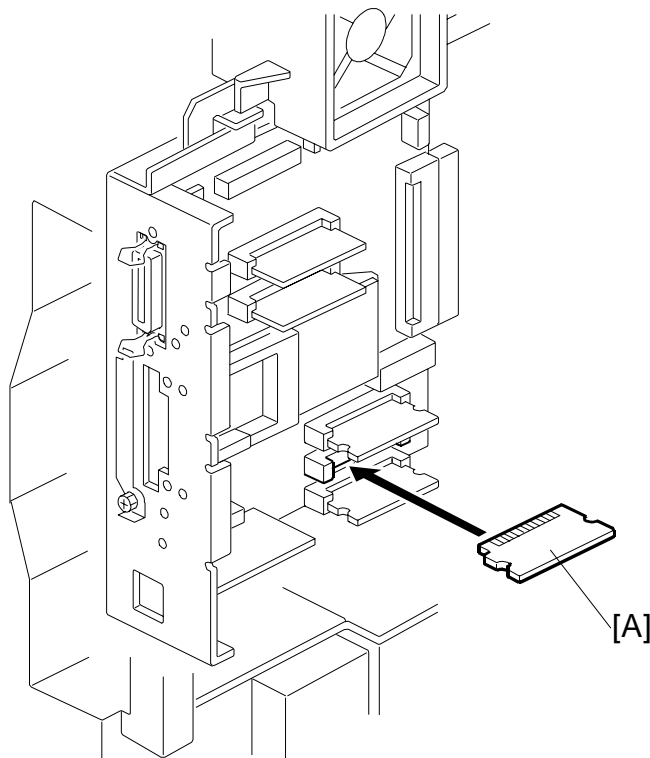

B529I313.WMF

1. Remove the rear cover and controller board cover (☛ steps 1 and 2 of the printer/scanner installation section).
2. Install the PostScript DIMM [A] on the controller board.
3. Replace the controller board cover and rear cover.

1.3.2 IEEE1394 INTERFACE (G539)

⚠ CAUTION

Unplug the main machine power cord before starting the following procedure.

Installation

NOTE: To install the IEEE1394 option, the printer option (B463 or B529) must be installed first (☛ 1.2).
The wireless LAN board and the IEEE1394 interface board cannot both be installed in the same machine. If the wireless LAN board has been installed, remove it.

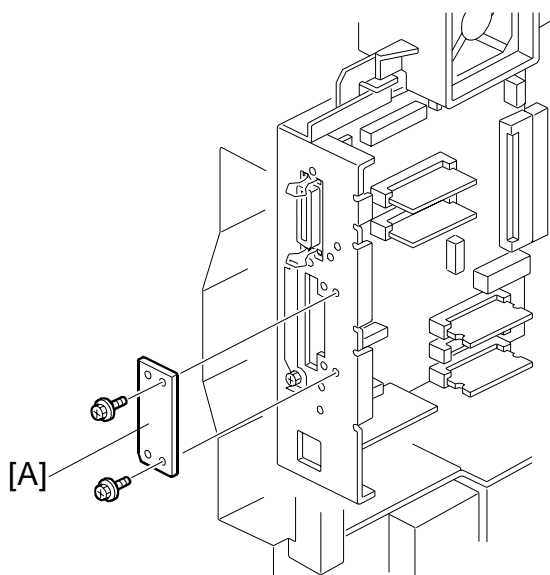

B529I309.WMF

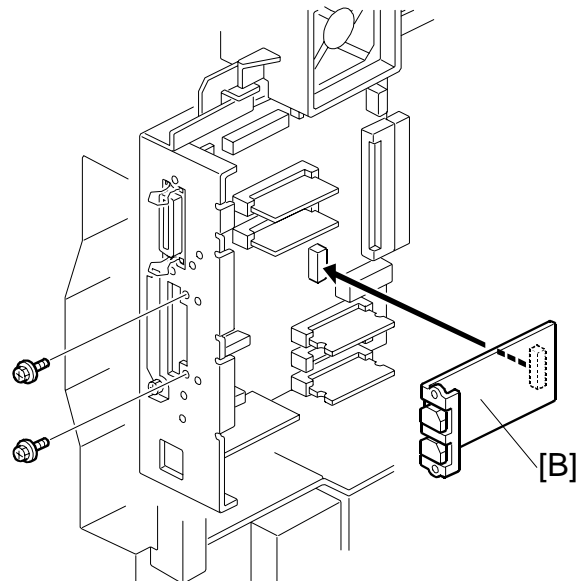

B529I310.WMF

1. Remove the rear cover and controller board cover (☛ steps 1 and 2 of the printer/scanner installation section).
2. If the cover plate [A] has been installed, remove it (☛ x 2).
3. Attach the IEEE1394 board [B] to the controller board (☛ x 2).
4. Replace the controller board cover and rear cover.

1.3.3 WIRELESS LAN (B515)

⚠ CAUTION
Unplug the main machine power cord before starting the following procedure.

NOTE: To install the wireless LAN option, the printer option (B463 or B529) must be installed first (☛ 1.2).
 The wireless LAN board and the IEEE1394 interface board cannot both be installed in the same machine. If the IEEE1394 board has been installed, remove it.

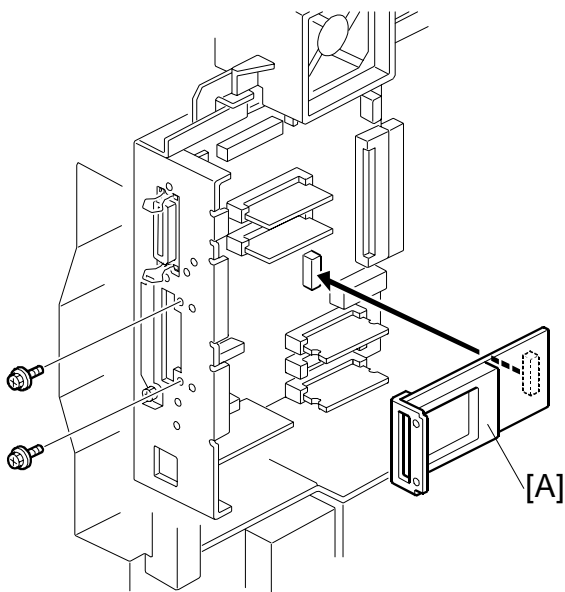

B529I311.WMF

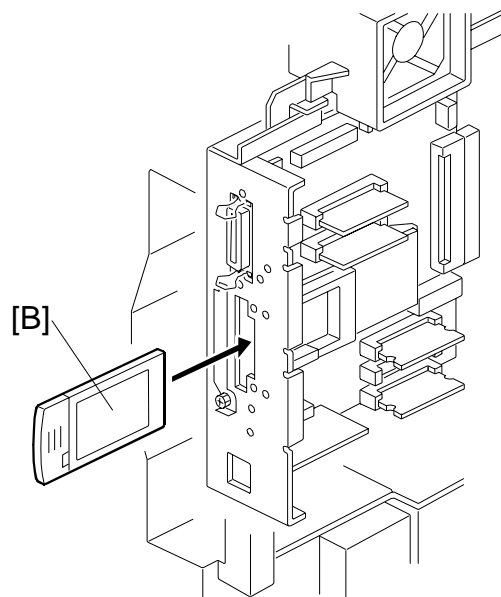

B529I312.WMF

1. Remove the rear cover and controller board cover (☛ steps 1 and 2 of the printer/scanner installation section).
2. Attach the wireless LAN board [A] to the controller board (☛ x 2).
3. Install the wireless LAN card [B].
4. Replace the controller board cover and rear cover.

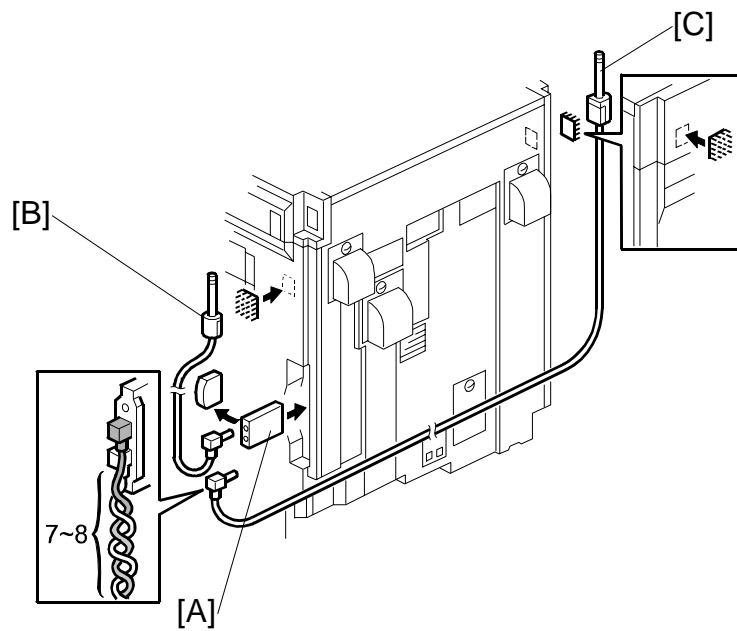

B529I008.WMF

If wireless LAN reception is not very good, install the extended antenna.

5. Remove the wireless LAN card [A] from the machine.
6. Remove the standard antenna [B] from the wireless LAN card.
7. Install the extended antenna [C] on the LAN card, as shown.
NOTE: The antenna jack must be at the bottom end.
8. Twine the extended-antenna wires seven or eight times.
9. Peel off the backing of the double-sided tape attached to the antenna, and stick the antenna on the machine.

1.4 CHECKING THE CONNECTIONS

1. Plug in the power cord and turn on the main switch.
2. Enter the printer user mode and print the configuration page.
(User Tools/ Printer Settings/ List Test Print/ Config. Page)
The same data can also be printed using the printer service mode.
("Print Summary": SP1-004)

All installed options are listed in the "System Reference" column.

2. TROUBLESHOOTING

2.1 CONTROLLER ERRORS

Refer to section 7.1 of the main unit service manual for descriptions on SC code information because the GW architecture includes controller SC codes in the main unit SC code table.

2.2 LEDS AND TEST POINTS

LEDs and test points are not used for this option (except for the NIB  section 4.4).

3. SERVICE TABLES

3.1 SERVICE PROGRAM MODE

CAUTION

Before accessing the service menu, do the following:

Confirm that there is no print data in the printer buffer (the Data In LED must not be lit or blinking).

If there is some data in the buffer, wait until all data has been printed.

CAUTION

Never turn off the main power switch when the power LED is lit or flashing. To avoid damaging the hard disk or memory, press the operation power switch to switch the power off, wait for the power LED to go off, and then switch the main power switch off.

Service
Tables

NOTE: The main power LED () lights or flashes while the platen cover or ARDF is open, while the main unit is communicating with a facsimile or the network server, or while the machine is accessing the hard disk or memory for reading or writing data.

3.1.1 ENABLING AND DISABLING SERVICE PROGRAM MODE

Entering the SP mode



1. Press the Clear Mode key.



2. Use the keypad to enter "107".



3. Hold down Clear/Stop for at least 3 seconds.

4. Enter the Service Mode.

Printer SP

Press "Printer SP" to enter printer SP mode.

Scanner SP

Press "Scanner SP" to enter scanner SP mode.

NOTE: If you switch the machine off, any jobs stored on the hard disk using the sample print and protected print features will be deleted. Check first if there are any jobs stored with these features (Printer mode: View Sample Print Jobs/View Locked Print Job).

Exiting the Service Mode

Press "Exit" on the LCD panel to exit from the service mode.

3.2 PRINTER SERVICE MODE

3.2.1 SERVICE MODE TABLE

Service Table Key

Notation	What it means
[range / default / step]	Example: [-9 ~ +9 / +3.0 / 0.1 mm step]. The setting can be adjusted in the range ± 9 , value reset to +3.0 after an NVRAM reset, and the value can be changed in 0.1 mm steps with each key press.
italics	Comments added for your reference.
*	This value is stored in NVRAM. After a RAM reset, the default value (factory setting) is restored.
DFU	Denotes "Design or Factory Use". Do not change this value



SP1	Mode Number	Function / [Setting]	
001	BitSw#1 Set		
	1	Adjusts bit switch settings. Note: Currently the bit switches are not being used.	
	2		
	3		
	4		
003	Clear Setting		
	1	Initialize Printer System	Initializes settings in the "System" menu of the user mode.
	2	Clear CSS counter	DFU
	3	Delete Program	DFU
004	Print Summary		
	1	Prints the printer summary sheet (An error log is printed in addition to the configuration page).	
005	Display Version		
	1	Displays the version of the controller firmware.	
101	Data Recall		
	1	Factory	Recalls a set of gamma settings.
	2	Previous	
	3	Current	
	4	ACC	
102	Resolution Settings		
	1	Selects the printing mode (resolution) for the printer gamma adjustment. 1800x1200 Photo 1800x600 Text 1800x600 Graph 600x600 Photo 600x600 Text	

SP1	Mode Number	Function / [Setting]
103	Test Page	
	1	Color Gray Scale
	2	Color Pattern
Prints the <i>Color Calibration Test Sheet</i> or <i>Color Test Pattern</i> to check the color balance before and after toner control adjustment (gamma adjustment). <i>For toner control adjustment, see SP1-104 and SP1-105.</i>		
104	Gamma Adjustment	
	1	Black: Highlight
	2	Black: Shadow
	3	Black: Middle
	4	Black: IDmax
	21	Cyan: Highlight
	22	Cyan: Shadow
	23	Cyan: Middle
	24	Cyan: IDmax
	41	Magenta: Highlight
	42	Magenta: Shadow
	43	Magenta: Middle
	44	Magenta: IDmax
	61	Yellow: Highlight
	62	Yellow: Shadow
63	Yellow: Middle	
64	Yellow: IDmax	
Adjusts the printer gamma for the mode selected in the "Mode Selection" menu. [0 to 30 / 15 / 1/step] <i>For the Color Calibration Test Sheet and Color Test Pattern, see SP1-103. For saving adjusted values, see SP1-105.</i>		
105	Save Tone Control Value	
	1	
Stores the print gamma adjusted with the "Gamma Adj." menu item as the current setting. Before the machine stores the new 'current setting', it moves the data currently stored as the 'current setting' to the 'previous setting' memory storage location.		
106	Toner Limit	
	1	Toner Limit Photo
	2	Toner Limit Text
Adjusts the maximum toner amount for image development. [100 ~ 400 / 250 / 1%/step] [100 ~ 400 / 180 / 1%/step]		
107	Factory Test Print	
	1	
DFU		

3.2.2 SP MODES RELATED TO THE PRINTER CONTROLLER

The following SP modes are located in the copier SP mode.

☛ Section 4.1 of the main unit service manual.

SP No.	Description	Function and Setting
5104	A3/DLT Double Count	Specifies whether the counter is doubled for A3/DLT. 0: No, 1: Yes If Yes is selected, the total counter and the current user code counter count up twice when A3 or DLT paper is used.
5801	Memory All Clear	Resets data for process control and all software counters, and returns all modes and adjustments to their defaults values.
5907	Plug & Play	Selects the brand name and the production name for Windows Plug & Play. This information is stored in NVRAM.
7832	Detailed Display of Self-Diagnostics	Displays the controller self-diagnostic result.

3.3 SCANNER SERVICE MODE

3.3.1 SCANNER PROGRAM MODE TABLE

SP1-XXX (System and Others)

1	Mode No. (Class 1, 2, and 3)	Function / [Setting]
001	[System]	
	1	Model Name Displays the model name.
	2	Scanner Firmware Version Displays the scanner firmware version.
	3	Scanner Firmware Number Displays the firmware's part number.
	4	Detail Model Name Displays the detail model name.
002	[Error Log Display]	
	1	Error Log Display Displays the error log data.
004	[Compression Type]	
	1	Compression Type Selects the compression type for binary picture processing. [1 to 3 / <u>3</u> / 1/step] 1: MH, 2: MR, 3: MMR
005	[Erase margin]	
	1	Erase Margin Creates an erase margin for all edges of the scanned image. <i>If the machine has scanned the edge of the original, create a margin.</i> [0 to 5 / <u>0</u> / 1 mm/step]
006	[Auto Reset Timer]	
	1	Auto Reset Timer Adjusts the auto reset timer for the scanner function. <i>If this is "0", the auto reset function is disabled.</i> [0 to 99 / <u>60</u> / 1 sec/step]

Service Tables

SP2-XXX (Scanning-image quality)

2	Mode Number (Class 1, 2, and 3)	Function / [Setting]
002	[Text (print) mode settings]	
	1	MTF Filter Coefficient (Main scan) Selects the MTF filter coefficient in the main scan direction for Text mode. <i>Select a higher number for a stronger filter.</i> <i>If this is "0", the MTF filter is not applied.</i> [0 to 15 / <u>7</u> / 1/step] DFU
	2	MTF Filter Coefficient (Sub scan) As above, for sub scan [0 to 13 / <u>6</u> / 1/step] DFU
	3	Smoothing Filter Selects the smoothing pattern for Text mode when using binary picture processing mode. <i>A larger value could cause moiré to appear in the image.</i> [0 to 7 / <u>0</u> / 1/step] DFU
	4	Scanner Gamma Selects the scanner gamma type for Text mode when using binary picture processing mode. [0 to 6 / <u>4</u> / 1/step] DFU 0: Standard 1: Smooth 2: Clearly 3: Liner 4: Text image for the delivery function 5: Text/photo image for the delivery function 6: Photo image for the delivery function
	5	Notch No.7(Lighter): Brightness Adjusts the image density for each image density level for Text mode when using binary picture processing mode. [0 to 255 / <u>104</u> / 1/step] DFU
	6	Notch No.7(Lighter): Contrast [0 to 255 / <u>128</u> / 1/step] DFU
	7	Notch No.7(Lighter): Threshold [0 to 255 / <u>160</u> / 1/step] DFU
	8	Notch No.6: Brightness [0 to 255 / <u>128</u> / 1/step] DFU
	9	Notch No.6: Contrast [0 to 255 / <u>128</u> / 1/step] DFU
	10	Notch No.6: Threshold [0 to 255 / <u>145</u> / 1/step] DFU
	11	Notch No.5: Brightness [0 to 255 / <u>128</u> / 1/step] DFU
	12	Notch No.5: Contrast [0 to 255 / <u>128</u> / 1/step] DFU
	13	Notch No.5: Threshold [0 to 255 / <u>135</u> / 1/step] DFU
	14	Notch No.4(Middle): Brightness [0 to 255 / <u>128</u> / 1/step] DFU
	15	Notch No. 4(Middle): Contrast [0 to 255 / <u>128</u> / 1/step] DFU
	16	Notch No. 4(Middle): Threshold [0 to 255 / <u>128</u> / 1/step] DFU
	17	Notch No.3: Brightness [0 to 255 / <u>128</u> / 1/step] DFU
	18	Notch No.3: Contrast Adjusts the image density for each image density level for Text mode when using binary picture processing mode. [0 to 255 / <u>128</u> / 1/step] DFU
	19	Notch No.3: Threshold [0 to 255 / <u>100</u> / 1/step] DFU
	20	Notch No.2: Brightness [0 to 255 / <u>128</u> / 1/step] DFU

2	Mode Number (Class 1, 2, and 3)	Function / [Setting]
002	21	Notch No.2: Contrast [0 to 255 / <u>128</u> / 1/step] DFU
	22	Notch No.2: Threshold [0 to 255 / <u>85</u> / 1/step] DFU
	23	Notch No. 1(Darker): Brightness [0 to 255 / <u>128</u> / 1/step] DFU
	24	Notch No. 1(Darker): Contrast [0 to 255 / <u>128</u> / 1/step] DFU
	25	Notch No. 1(Darker): Threshold [0 to 255 / <u>70</u> / 1/step] DFU
003	[Text (OCR) mode settings]	
	1	MTF Filter Coefficient (Main scan) Selects the MTF filter coefficient in the main scan direction for Text mode. <i>Select a higher number for a stronger filter. If this is "0", the MTF filter is not applied.</i> [0 to 15 / <u>7</u> / 1/step] DFU
	2	MTF Filter Coefficient (Sub scan) As above, for sub scan [0 to 13 / <u>6</u> / 1/step] DFU
	3	Smoothing Filter Selects the smoothing pattern for Text mode when using binary picture processing mode. <i>A larger value could cause moiré to appear in the image.</i> [0 to 7 / <u>0</u> / 1/step] DFU
	4	Scanner Gamma Selects the scanner gamma type for Text mode when using binary picture processing mode. [0 to 6 / <u>4</u> / 1/step] DFU 0: Standard 1: Smooth 2: Clearly 3: Liner 4: Text image for the delivery function 5: Text/photo image for the delivery function 6: Photo image for the delivery function
	5	Notch No.7(Lighter): Brightness Adjusts the image density for each image density level for Text mode when using binary picture processing mode. [0 to 255 / <u>104</u> / 1/step] DFU
	6	Notch No.7(Lighter): Contrast [0 to 255 / <u>128</u> / 1/step] DFU
	7	Notch No.7(Lighter): Threshold [0 to 255 / <u>160</u> / 1/step] DFU
	8	Notch No.6: Brightness [0 to 255 / <u>128</u> / 1/step] DFU
	9	Notch No.6: Contrast [0 to 255 / <u>128</u> / 1/step] DFU
	10	Notch No.6: Threshold [0 to 255 / <u>145</u> / 1/step] DFU
	11	Notch No.5: Brightness [0 to 255 / <u>128</u> / 1/step] DFU
	12	Notch No.5: Contrast [0 to 255 / <u>128</u> / 1/step] DFU
	13	Notch No.5: Threshold [0 to 255 / <u>135</u> / 1/step] DFU
	14	Notch No.4(Middle): Brightness [0 to 255 / <u>128</u> / 1/step] DFU
	15	Notch No. 4(Middle): Contrast [0 to 255 / <u>128</u> / 1/step] DFU
	16	Notch No. 4(Middle): Threshold [0 to 255 / <u>128</u> / 1/step] DFU
17	Notch No.3: Brightness [0 to 255 / <u>128</u> / 1/step] DFU	

2	Mode Number (Class 1, 2, and 3)		Function / [Setting]
003	18	Notch No.3: Contrast	Adjusts the image density for each image density level for Text mode when using binary picture processing mode. [0 to 255 / <u>128</u> / 1/step] DFU
	19	Notch No.3: Threshold	[0 to 255 / <u>100</u> / 1/step] DFU
	20	Notch No.2: Brightness	[0 to 255 / <u>128</u> / 1/step] DFU
	21	Notch No.2: Contrast	[0 to 255 / <u>128</u> / 1/step] DFU
	22	Notch No.2: Threshold	[0 to 255 / <u>85</u> / 1/step] DFU
	23	Notch No. 1(Darker): Brightness	[0 to 255 / <u>128</u> / 1/step] DFU
	24	Notch No. 1(Darker): Contrast	[0 to 255 / <u>128</u> / 1/step] DFU
	25	Notch No. 1(Darker): Threshold	[0 to 255 / <u>70</u> / 1/step] DFU
004	[Text/Photo mode settings]		
	1	MTF Filter Coefficient (Main scan)	Selects the MTF filter coefficient in the main scan direction for Text/Photo mode. <i>Select a higher number for a stronger filter. If this is "0", the MTF filter is not applied.</i> [0 to 15 / <u>4</u> / 1/step] DFU
	2	MTF Filter Coefficient (Sub scan)	As above, for sub scan [0-13 / <u>4</u> / 1/step] DFU
	3	Smoothing Filter	Selects the smoothing pattern for Text/Photo mode when using binary picture processing mode. <i>A larger value could cause moiré to appear in the image.</i> [0 to 7 / <u>0</u> / 1/step] DFU
	4	Scanner Gamma	Selects the scanner gamma type for Text/Photo mode when using binary picture processing mode. [0 to 6 / <u>5</u> / 1/step] DFU
	5	Notch No.7(Lighter): Brightness	Adjusts the image density for each image density level for Text mode when using binary picture processing mode. [0 to 255 / <u>128</u> / 1/step] DFU
	6	Notch No.7(Lighter): Contrast	[0 to 255 / <u>128</u> / 1/step] DFU
	7	Notch No.7(Lighter): Threshold	[0 to 255 / <u>160</u> / 1/step] DFU
	8	Notch No.6: Brightness	[0 to 255 / <u>128</u> / 1/step] DFU
	9	Notch No.6: Contrast	[0 to 255 / <u>128</u> / 1/step] DFU
	10	Notch No.6: Threshold	[0 to 255 / <u>145</u> / 1/step] DFU
	11	Notch No.5: Brightness	[0 to 255 / <u>128</u> / 1/step] DFU
	12	Notch No.5: Contrast	[0 to 255 / <u>128</u> / 1/step] DFU
	13	Notch No.5: Threshold	[0 to 255 / <u>135</u> / 1/step] DFU
	14	Notch No.4(Middle): Brightness	[0 to 255 / <u>128</u> / 1/step] DFU
	15	Notch No. 4(Middle): Contrast	[0 to 255 / <u>128</u> / 1/step] DFU
	16	Notch No. 4(Middle): Threshold	[0 to 255 / <u>128</u> / 1/step] DFU
	17	Notch No.3: Brightness	[0 to 255 / <u>128</u> / 1/step] DFU

2	Mode Number (Class 1, 2, and 3)		Function / [Setting]
004	18	Notch No.3: Contrast	Adjusts the image density for each image density level for Text mode when using binary picture processing mode. [0 to 255 / <u>128</u> / 1/step] DFU
	19	Notch No.3: Threshold	[0 to 255 / <u>100</u> / 1/step] DFU
	20	Notch No.2: Brightness	[0 to 255 / <u>128</u> / 1/step] DFU
	21	Notch No.2: Contrast	[0 to 255 / <u>128</u> / 1/step] DFU
	22	Notch No.2: Threshold	[0 to 255 / <u>85</u> / 1/step] DFU
	23	Notch No. 1(Darker): Brightness	[0 to 255 / <u>128</u> / 1/step] DFU
	24	Notch No. 1(Darker): Contrast	[0 to 255 / <u>128</u> / 1/step] DFU
	25	Notch No. 1(Darker): Threshold	[0 to -255 / <u>70</u> / 1/step] DFU
005	[Photo mode settings]		
	1	MTF Filter Coefficient (Main scan)	Selects the MTF filter coefficient in the main scan direction for Photo mode. <i>Select a higher number for a stronger filter. If this is "0", the MTF filter is not applied.</i> [0 to 15 / <u>0</u> / 1/step] DFU
	2	MTF Filter Coefficient (Sub scan)	As above, for sub scan [0 to 13 / <u>0</u> / 1/step] DFU
	3	Smoothing Filter	Selects the smoothing pattern for Photo mode when using binary picture processing mode. <i>A larger value could cause moiré to appear in the image.</i> [0 to 7 / <u>0</u> / 1/step] DFU
	4	Scanner Gamma	Selects the scanner gamma type for Photo mode when using binary picture processing mode. [0 to 6 / <u>6</u> / 1/step] DFU
	5	Dither Matrix Filter	Selects the dither matrix type for Photo mode when using binary picture processing mode. [1 to 26 / 4 / 1 step] DFU
	6	Notch No.7(Lighter): Brightness	Adjusts the image density for each image density level for Text mode when using binary picture processing mode. [0 to 255 / <u>128</u> / 1/step] DFU
	7	Notch No.7(Lighter): Contrast	[0 to 255 / <u>128</u> / 1/step] DFU
	8	Notch No.7(Lighter): Threshold	[0 to 255 / <u>160</u> / 1/step] DFU
	9	Notch No.6: Brightness	[0 to 255 / <u>128</u> / 1/step] DFU
	10	Notch No.6: Contrast	[0 to 255 / <u>128</u> / 1/step] DFU
	11	Notch No.6: Threshold	[0 to 255 / <u>145</u> / 1/step] DFU
	12	Notch No.5: Brightness	[0 to 255 / <u>128</u> / 1/step] DFU
	13	Notch No.5: Contrast	[0 to 255 / <u>128</u> / 1/step] DFU
	14	Notch No.5: Threshold	[0 to 255 / <u>135</u> / 1/step] DFU
	15	Notch No.4(Middle): Brightness	[0 to 255 / <u>128</u> / 1/step] DFU
	16	Notch No. 4(Middle): Contrast	[0 to 255 / <u>128</u> / 1/step] DFU

2	Mode Number (Class 1, 2, and 3)	Function / [Setting]
005	17	Notch No. 4(Middle): Threshold [0 to 255 / <u>128</u> / 1/step] DFU
	18	Notch No.3: Brightness [0 to 255 / <u>128</u> / 1/step] DFU
	19	Notch No.3: Contrast Adjusts the image density for each image density level for Text mode when using binary picture processing mode. [0 to 255 / <u>128</u> / 1/step] DFU
	20	Notch No.3: Threshold [0 to 255 / <u>100</u> / 1/step] DFU
	21	Notch No.2: Brightness [0 to 255 / <u>128</u> / 1/step] DFU
	22	Notch No.2: Contrast [0 to 255 / <u>128</u> / 1/step] DFU
	23	Notch No.2: Threshold [0 to 255 / <u>85</u> / 1/step] DFU
	24	Notch No. 1(Darker): Brightness [0 to 255 / <u>128</u> / 1/step] DFU
	25	Notch No. 1(Darker): Contrast [0 to 255 / <u>128</u> / 1/step] DFU
	26	Notch No. 1(Darker): Threshold [0 to 255 / <u>70</u> / 1/step] DFU
006	[Gray – scale mode settings]	
	1	MTF Filter Coefficient (Main scan) Selects the MTF filter coefficient in the main scan direction when using grayscale processing mode. <i>Select a higher number for a stronger filter.</i> <i>If this is "0", the MTF filter is not applied</i> [0 to 15 / <u>0</u> / 1 step] DFU
	2	MTF Filter Coefficient (Sub scan) As above, for sub scan [0 to 13 / <u>0</u> / 1 step] DFU
	3	Smoothing Filter Selects the smoothing pattern when using grayscale processing mode. <i>A larger value could cause moiré to appear in the image.</i> [0 to 7 / <u>0</u> / 1/step] DFU
	4	Scanner Gamma Selects the scanner gamma type when using grayscale processing mode. [0 to 6 / <u>3</u> / 1/step] DFU
	5	Notch No.7(Lighter): Brightness Adjusts the image density for each image density level for Text mode when using binary picture processing mode. [0 to 255 / <u>128</u> / 1/step] DFU
	6	Notch No.7(Lighter): Contrast [0 to 255 / <u>128</u> / 1/step] DFU
	7	Notch No.7(Lighter): Threshold [0 to 255 / <u>160</u> / 1/step] DFU
	8	Notch No.6: Brightness [0 to 255 / <u>128</u> / 1/step] DFU
	9	Notch No.6: Contrast [0 to 255 / <u>128</u> / 1/step] DFU
	10	Notch No.6: Threshold [0 to 255 / <u>145</u> / 1/step] DFU
	11	Notch No.5: Brightness [0 to 255 / <u>128</u> / 1/step] DFU
	12	Notch No.5: Contrast [0 to 255 / <u>128</u> / 1/step] DFU
	13	Notch No.5: Threshold [0 to 255 / <u>135</u> / 1/step] DFU
	14	Notch No.4(Middle): Brightness [0 to 255 / <u>128</u> / 1/step] DFU
15	Notch No. 4(Middle): Contrast [0 to 255 / <u>128</u> / 1/step] DFU	

2	Mode Number (Class 1, 2, and 3)		Function / [Setting]
006	16	Notch No. 4(Middle): Threshold	[0 to 255 / <u>128</u> / 1/step] DFU
	17	Notch No.3: Brightness	[0 to 255 / <u>128</u> / 1/step] DFU
	18	Notch No.3: Contrast	Adjusts the image density for each image density level for Text mode when using binary picture processing mode. [0 to 255 / <u>128</u> / 1/step] DFU
	19	Notch No.3: Threshold	[0 to 255 / <u>100</u> / 1/step] DFU
	20	Notch No.2: Brightness	[0 to 255 / <u>128</u> / 1/step] DFU
	21	Notch No.2: Contrast	[0 to 255 / <u>128</u> / 1/step] DFU
	22	Notch No.2: Threshold	[0 to 255 / <u>85</u> / 1/step] DFU
	23	Notch No. 1(Darker): Brightness	[0 to 255 / <u>128</u> / 1/step] DFU
	24	Notch No. 1(Darker): Contrast	[0 to 255 / <u>128</u> / 1/step] DFU
	25	Notch No. 1(Darker): Threshold	[0 to 255 / <u>70</u> / 1/step] DFU
007	[Full Color (text) settings]		
	1	MTF Filter Coefficient (Main scan)	Selects the MTF filter coefficient in the main scan direction when using grayscale processing mode. <i>Select a higher number for a stronger filter.</i> <i>If this is "0", the MTF filter is not applied</i> [0 to 15 / <u>0</u> / 1/step] DFU
	2	MTF Filter Coefficient (Sub scan)	As above, for sub scan [0 to 13 / <u>0</u> / 1/step] DFU
	3	Smoothing Filter	Selects the smoothing pattern when using grayscale processing mode. <i>A larger value could cause moiré to appear in the image.</i> [0 to 7 / <u>0</u> / 1/step] DFU
	4	R-Gamma Curve	Adjusts the scanner gamma for RGB. [0 to 9 / <u>7</u> / 1/step] DFU
	5	G-Gamma Curve	
	6	B-Gamma Curve	
	7	Notch No.7(Lighter): R - Brightness	Adjusts the image density for each image density level for Text mode when using binary picture processing mode. [0 to 255 / <u>195</u> / 1/step] DFU
	8	Notch No.7(Lighter): G - Brightness	[0 to 255 / <u>194</u> / 1/step] DFU
	9	Notch No.7(Lighter): B - Brightness	[0 to 255 / <u>195</u> / 1/step] DFU
	10	Notch No.7(Lighter): R - Contrast	[0 to 255 / <u>185</u> / 1/step] DFU
	11	Notch No.7(Lighter): G - Contrast	[0 to 255 / <u>184</u> / 1/step] DFU
	12	Notch No.7(Lighter): B - Contrast	[0 to 255 / <u>185</u> / 1/step] DFU
	13	Notch No.7(Lighter): R - Threshold	[0 to 255 / <u>128</u> / 1/step] DFU
14	Notch No.7(Lighter): G - Threshold	[0 to 255 / <u>128</u> / 1/step] DFU	

2	Mode Number (Class 1, 2, and 3)	Function / [Setting]	
007	15	Notch No.7(Lighter): B - Threshold	[0 to 255 / <u>128</u> / 1/step] DFU
	16	Notch No.6: R - Brightness	[0 to 255 / <u>177</u> / 1/step] DFU
	17	Notch No.6: G - Brightness	[0 to 255 / <u>174</u> / 1/step] DFU
	18	Notch No.6: B - Brightness	[0 to 255 / <u>177</u> / 1/step] DFU
	19	Notch No.6: R - Contrast	[0 to 255 / <u>168</u> / 1/step] DFU
	20	Notch No.6 G - Contrast	[0 to 255 / <u>164</u> / 1/step] DFU
	21	Notch No.6: B - Contrast	[0 to 255 / <u>168</u> / 1/step] DFU
	22	Notch No.6: R - Threshold	[0 to 255 / <u>128</u> / 1/step] DFU
	23	Notch No.6: G - Threshold	[0 to 255 / <u>128</u> / 1/step] DFU
	24	Notch No.6: B - Threshold	[0 to 255 / <u>128</u> / 1/step] DFU
	25	Notch No.5: R - Brightness	[0 to 255 / <u>172</u> / 1/step] DFU
	26	Notch No.5: G - Brightness	[0 to 255 / <u>165</u> / 1/step] DFU
	27	Notch No.5: B - Brightness	[0 to 255 / <u>168</u> / 1/step] DFU
	28	Notch No.5: R - Contrast	[0 to 255 / <u>165</u> / 1/step] DFU
	29	Notch No.5 G - Contrast	[0 to 255 / <u>161</u> / 1/step] DFU
	30	Notch No.5: B - Contrast	[0 to 255 / <u>164</u> / 1/step] DFU
	31	Notch No.5: R - Threshold	[0 to 255 / <u>128</u> / 1/step] DFU
	32	Notch No.5: G - Threshold	[0 to 255 / <u>128</u> / 1/step] DFU
	33	Notch No.5: B - Threshold	[0 to 255 / <u>128</u> / 1/step] DFU
	34	Notch No.4(Middle): R - Brightness	[0 to 255 / <u>128</u> / 1/step] DFU
	35	Notch No. 4(Middle): G - Brightness	[0 to 255 / <u>128</u> / 1/step] DFU
	36	Notch No. 4(Middle): B - Brightness	[0 to 255 / <u>128</u> / 1/step] DFU
	37	Notch No. 4(Middle): R - Contrast	[0 to 255 / <u>128</u> / 1/step] DFU
	38	Notch No. 4(Middle): G - Contrast	[0 to 255 / <u>128</u> / 1/step] DFU
	39	Notch No. 4(Middle): B - Contrast	[0 to 255 / <u>128</u> / 1/step] DFU
	40	Notch No. 4(Middle): R - Threshold	[0 to 255 / <u>128</u> / 1/step] DFU
	41	Notch No. 4(Middle): G - Threshold	[0 to 255 / <u>128</u> / 1/step] DFU
	42	Notch No. 4(Middle): B - Threshold	[0 to 255 / <u>128</u> / 1/step] DFU
	43	Notch No.3: R - Brightness	[0 to 255 / <u>125</u> / 1/step] DFU

2	Mode Number (Class 1, 2, and 3)	Function / [Setting]	
007	44	Notch No.3: G - Brightness	[0 to 255 / <u>127</u> / 1/step] DFU
	45	Notch No.3: B - Brightness	[0 to 255 / <u>127</u> / 1/step] DFU
	46	Notch No.3: R - Contrast	[0 to 255 / <u>136</u> / 1/step] DFU
	47	Notch No.3 G - Contrast	[0 to 255 / <u>134</u> / 1/step] DFU
	48	Notch No.3: B - Contrast	[0 to 255 / <u>134</u> / 1/step] DFU
	49	Notch No.3: R - Threshold	[0 to 255 / <u>128</u> / 1/step] DFU
	50	Notch No.3: G - Threshold	[0 to 255 / <u>128</u> / 1/step] DFU
	51	Notch No.3: B - Threshold	[0 to 255 / <u>128</u> / 1/step] DFU
	52	Notch No.2: R - Brightness	[0 to 255 / <u>124</u> / 1/step] DFU
	53	Notch No.2: G - Brightness	[0 to 255 / <u>126</u> / 1/step] DFU
	54	Notch No.2: B - Brightness	[0 to 255 / <u>126</u> / 1/step] DFU
	55	Notch No.2: R - Contrast	[0 to 255 / <u>140</u> / 1/step] DFU
	56	Notch No.2 G - Contrast	[0 to 255 / <u>138</u> / 1/step] DFU
	57	Notch No.2: B - Contrast	[0 to 255 / <u>138</u> / 1/step] DFU
	58	Notch No.2: R - Threshold	[0 to 255 / <u>128</u> / 1/step] DFU
	59	Notch No.2: G - Threshold	[0 to 255 / <u>128</u> / 1/step] DFU
	60	Notch No.2: B - Threshold	[0 to 255 / <u>128</u> / 1/step] DFU
	61	Notch No. 1(Darker): R - Brightness	[0 to 255 / <u>124</u> / 1/step] DFU
	62	Notch No. 1(Darker): G - Brightness	[0 to 255 / <u>125</u> / 1/step] DFU
	63	Notch No. 1(Darker): B - Brightness	[0 to 255 / <u>126</u> / 1/step] DFU
64	Notch No. 1(Darker): R - Contrast	[0 to 255 / <u>144</u> / 1/step] DFU	
65	Notch No. 1(Darker) G - Contrast	[0 to 255 / <u>144</u> / 1/step] DFU	
66	Notch No. 1(Darker): B - Contrast	[0 to 255 / <u>142</u> / 1/step] DFU	
67	Notch No. 1(Darker): R - Threshold	[0 to 255 / <u>128</u> / 1/step] DFU	
68	Notch No. 1(Darker): G - Threshold	[0 to 255 / <u>128</u> / 1/step] DFU	
69	Notch No. 1(Darker): B - Threshold	[0 to 255 / <u>128</u> / 1/step] DFU	
008	[Full Color (photo) settings]		
	1	MTF Filter Coefficient (Main scan)	Selects the MTF filter coefficient in the main scan direction when using grayscale processing mode. <i>Select a higher number for a stronger filter.</i> <i>If this is "0", the MTF filter is not applied</i> [0 to 15 / <u>0</u> / 1/step] DFU

2	Mode Number (Class 1, 2, and 3)		Function / [Setting]
008	2	MTF Filter Coefficient (Sub scan)	As above, for sub scan [0 to 13 / <u>0</u> / 1/step] DFU
	3	Smoothing Filter	Selects the smoothing pattern when using grayscale processing mode. <i>A larger value could cause moiré to appear in the image.</i> [0 to 7 / <u>0</u> / 1/step] DFU
	4	R-Gamma Curve	Adjusts the scanner gamma for RGB. [0 to 9 / <u>7</u> / 1/step] DFU
	5	G-Gamma Curve	
	6	B-Gamma Curve	
	7	Notch No.7(Lighter): R - Brightness	Adjusts the image density for each image density level for Text mode when using binary picture processing mode. [0 to 255 / <u>195</u> / 1/step] DFU
	8	Notch No.7(Lighter): G - Brightness	[0 to 255 / <u>194</u> / 1/step] DFU
	9	Notch No.7(Lighter): B - Brightness	[0 to 255 / <u>195</u> / 1/step] DFU
	10	Notch No.7(Lighter): R - Contrast	[0 to 255 / <u>185</u> / 1/step] DFU
	11	Notch No.7(Lighter): G - Contrast	[0 to 255 / <u>184</u> / 1/step] DFU
	12	Notch No.7(Lighter): B - Contrast	[0 to 255 / <u>185</u> / 1/step] DFU
	13	Notch No.7(Lighter): R - Threshold	[0 to 255 / <u>128</u> / 1/step] DFU
	14	Notch No.7(Lighter): G - Threshold	[0 to 255 / <u>128</u> / 1/step] DFU
	15	Notch No.7(Lighter): B - Threshold	[0 to 255 / <u>128</u> / 1/step] DFU
	16	Notch No.6: R - Brightness	[0 to 255 / <u>177</u> / 1/step] DFU
	17	Notch No.6: G - Brightness	[0 to 255 / <u>174</u> / 1/step] DFU
	18	Notch No.6: B - Brightness	[0 to 255 / <u>177</u> / 1/step] DFU
	19	Notch No.6: R - Contrast	[0 to 255 / <u>168</u> / 1/step] DFU
	20	Notch No.6 G - Contrast	[0 to 255 / <u>164</u> / 1/step] DFU
	21	Notch No.6: B - Contrast	[0 to 255 / <u>168</u> / 1/step] DFU
	22	Notch No.6: R - Threshold	[0 to 255 / <u>128</u> / 1/step] DFU
	23	Notch No.6: G - Threshold	[0 to 255 / <u>128</u> / 1/step] DFU
	24	Notch No.6: B - Threshold	[0 to 255 / <u>128</u> / 1/step] DFU
	25	Notch No.5: R - Brightness	[0 to 255 / <u>172</u> / 1/step] DFU
	26	Notch No.5: G - Brightness	[0 to 255 / <u>165</u> / 1/step] DFU
	27	Notch No.5: B - Brightness	[0 to 255 / <u>168</u> / 1/step] DFU
	28	Notch No.5: R - Contrast	[0 to 255 / <u>165</u> / 1/step] DFU

2	Mode Number (Class 1, 2, and 3)	Function / [Setting]
008	29	Notch No.5 G - Contrast [0 to 255 / <u>161</u> / 1/step] DFU
	30	Notch No.5: B - Contrast [0 to 255 / <u>164</u> / 1/step] DFU
	31	Notch No.5: R - Threshold [0 to 255 / <u>128</u> / 1/step] DFU
	32	Notch No.5: G - Threshold [0 to 255 / <u>128</u> / 1/step] DFU
	33	Notch No.5: B - Threshold [0 to 255 / <u>128</u> / 1/step] DFU
	34	Notch No.4(Middle): R - Brightness [0 to 255 / <u>128</u> / 1/step] DFU
	35	Notch No. 4(Middle): G - Brightness [0 to 255 / <u>128</u> / 1/step] DFU
	36	Notch No. 4(Middle): B - Brightness [0 to 255 / <u>128</u> / 1/step] DFU
	37	Notch No. 4(Middle): R - Contrast [0 to 255 / <u>128</u> / 1/step] DFU
	38	Notch No. 4(Middle): G - Contrast [0 to 255 / <u>128</u> / 1/step] DFU
	39	Notch No. 4(Middle): B - Contrast [0 to 255 / <u>128</u> / 1/step] DFU
	40	Notch No. 4(Middle): R - Threshold [0 to 255 / <u>128</u> / 1/step] DFU
	41	Notch No. 4(Middle): G - Threshold [0 to 255 / <u>128</u> / 1/step] DFU
	42	Notch No. 4(Middle): B - Threshold [0 to 255 / <u>128</u> / 1/step] DFU
	43	Notch No.3: R - Brightness [0 to 255 / <u>125</u> / 1/step] DFU
	44	Notch No.3: G - Brightness [0 to 255 / <u>127</u> / 1/step] DFU
	45	Notch No.3: B - Brightness [0 to 255 / <u>127</u> / 1/step] DFU
	46	Notch No.3: R - Contrast [0 to 255 / <u>136</u> / 1/step] DFU
	47	Notch No.3 G - Contrast [0 to 255 / <u>134</u> / 1/step] DFU
	48	Notch No.3: B - Contrast [0 to 255 / <u>134</u> / 1/step] DFU
	49	Notch No.3: R - Threshold [0 to 255 / <u>128</u> / 1/step] DFU
	50	Notch No.3: G - Threshold [0 to 255 / <u>128</u> / 1/step] DFU
	51	Notch No.3: B - Threshold [0 to 255 / <u>128</u> / 1/step] DFU
	52	Notch No.2: R - Brightness [0 to 255 / <u>124</u> / 1/step] DFU
	53	Notch No.2: G - Brightness [0 to 255 / <u>126</u> / 1/step] DFU
	54	Notch No.2: B - Brightness [0 to 255 / <u>126</u> / 1/step] DFU
	55	Notch No.2: R - Contrast [0 to 255 / <u>140</u> / 1/step] DFU
	56	Notch No.2 G - Contrast [0 to 255 / <u>138</u> / 1/step] DFU
57	Notch No.2: B - Contrast [0 to 255 / <u>138</u> / 1/step] DFU	
58	Notch No.2: R - Threshold [0 to 255 / <u>128</u> / 1/step] DFU	

2	Mode Number (Class 1, 2, and 3)		Function / [Setting]
008	59	Notch No.2: G - Threshold	[0 to 255 / <u>128</u> / 1/step] DFU
	60	Notch No.2: B - Threshold	[0 to 255 / <u>128</u> / 1/step] DFU
	61	Notch No. 1(Darker): R - Brightness	[0 to 255 / <u>124</u> / 1/step] DFU
	62	Notch No. 1(Darker): G - Brightness	[0 to 255 / <u>125</u> / 1/step] DFU
	63	Notch No. 1(Darker): B - Brightness	[0 to 255 / <u>126</u> / 1/step] DFU
	64	Notch No. 1(Darker): R - Contrast	[0 to 255 / <u>144</u> / 1/step] DFU
	65	Notch No. 1(Darker): G - Contrast	[0 to 255 / <u>144</u> / 1/step] DFU
	66	Notch No. 1(Darker): B - Contrast	[0 to 255 / <u>142</u> / 1/step] DFU
	67	Notch No. 1(Darker): R - Threshold	[0 to 255 / <u>128</u> / 1/step] DFU
	68	Notch No. 1(Darker): G - Threshold	[0 to 255 / <u>128</u> / 1/step] DFU
	69	Notch No. 1(Darker): B - Threshold	[0 to 255 / <u>128</u> / 1/step] DFU
	009	[Compression ratio of gray-scale]	
1		Compression ratio (Normal image)	Selects the compression ratio for grayscale processing mode (JPEG) for the three settings that can be selected at the operation panel. [5 to 95 / <u>50</u> / 1 /step]
2		Compression ratio (High quality image)	[5 to 95 / <u>60</u> / 1 /step]
3		Compression ratio (Low-quality image)	[5 to 95 / <u>40</u> / 1 /step]

3.4 FIRMWARE UPDATE PROCEDURE

Firmware updating procedure is described in section 5.2 of the main unit service manual.

3.5 POWER-ON SELF TEST

The controller tests the following devices at power-on. If an error is detected, an error code is stored in the controller board.

- CPU, ASIC and clock
 - Flash ROM
 - Resident and optional SDRAM
 - Parallel interface
 - NIB
 - IEEE1394 interface (if installed)
 - NVRAM
 - HDD
-
- Refer to section 4.1.2 of the main unit service manual for how to check the error codes (SP7-832).

3.6 SELF DIAGNOSTIC TEST

In addition to the power-on self test, you can set the machine in a more detailed diagnostic mode to test other components and conditions. It requires a loop-back connector (P/N: G0219350).

1. Turn off the machine and attach the loop-back connector to the parallel interface.
2. Turn on the machine while pressing the “On Line” key and “# Enter” key together.
3. The machine prints the diagnostic report automatically.
 - Refer to section 4.1.2 of the main unit service manual for how to check the error codes (SP7-832).

3.7 USER PROGRAM MODE

3.7.1 PRINTER USER PROGRAM MODE

Press the “Printer” key on the operation panel to enter the printer mode.
 Press the “User Tools/Counter ”, then select “Printer Settings” to change printer settings.

User Mode Tree

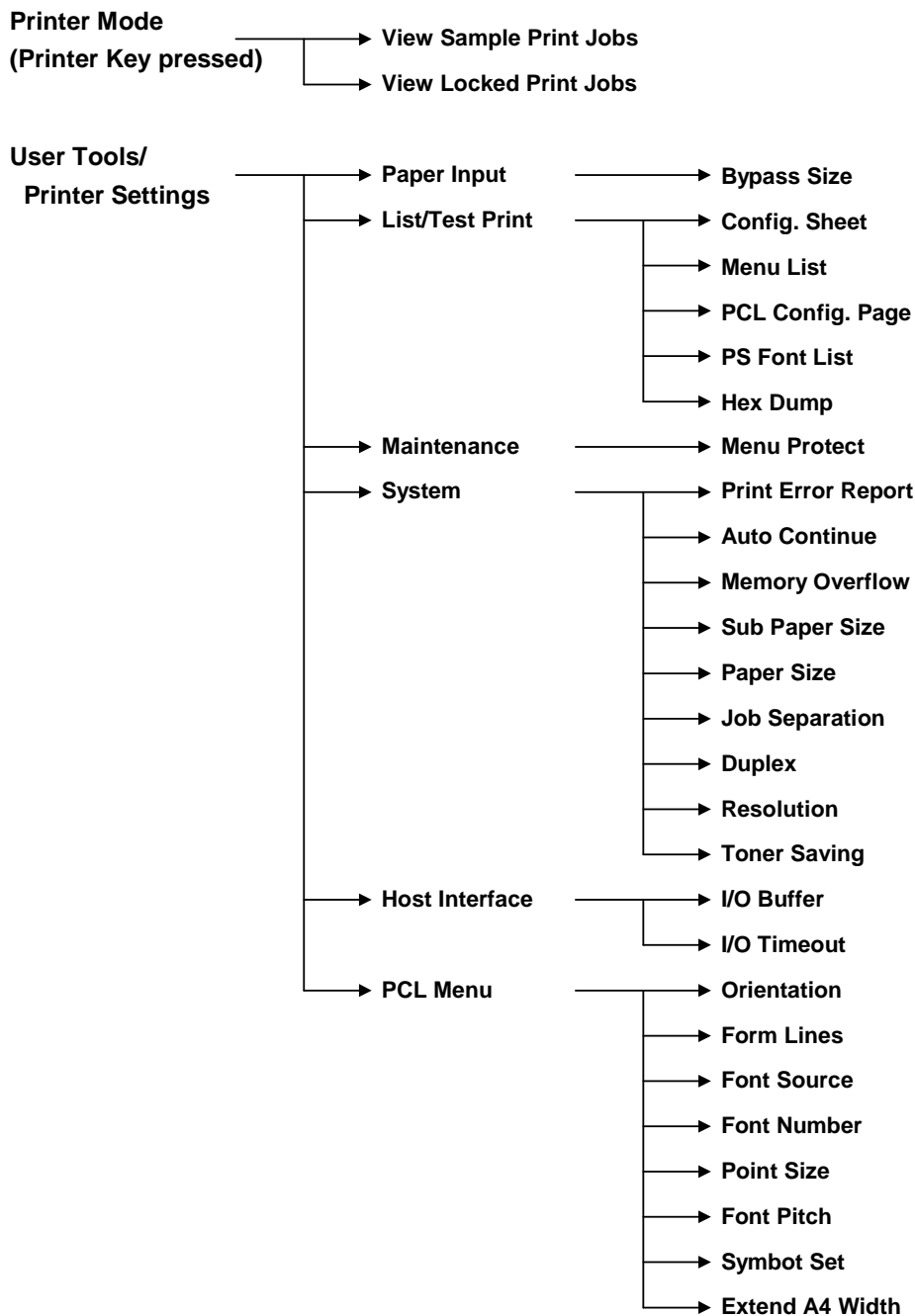

Scanner User Program Mode

Press the “User Tools/Counter ”, then select “Scanner Settings” to change scanner settings.

User Mode Tree

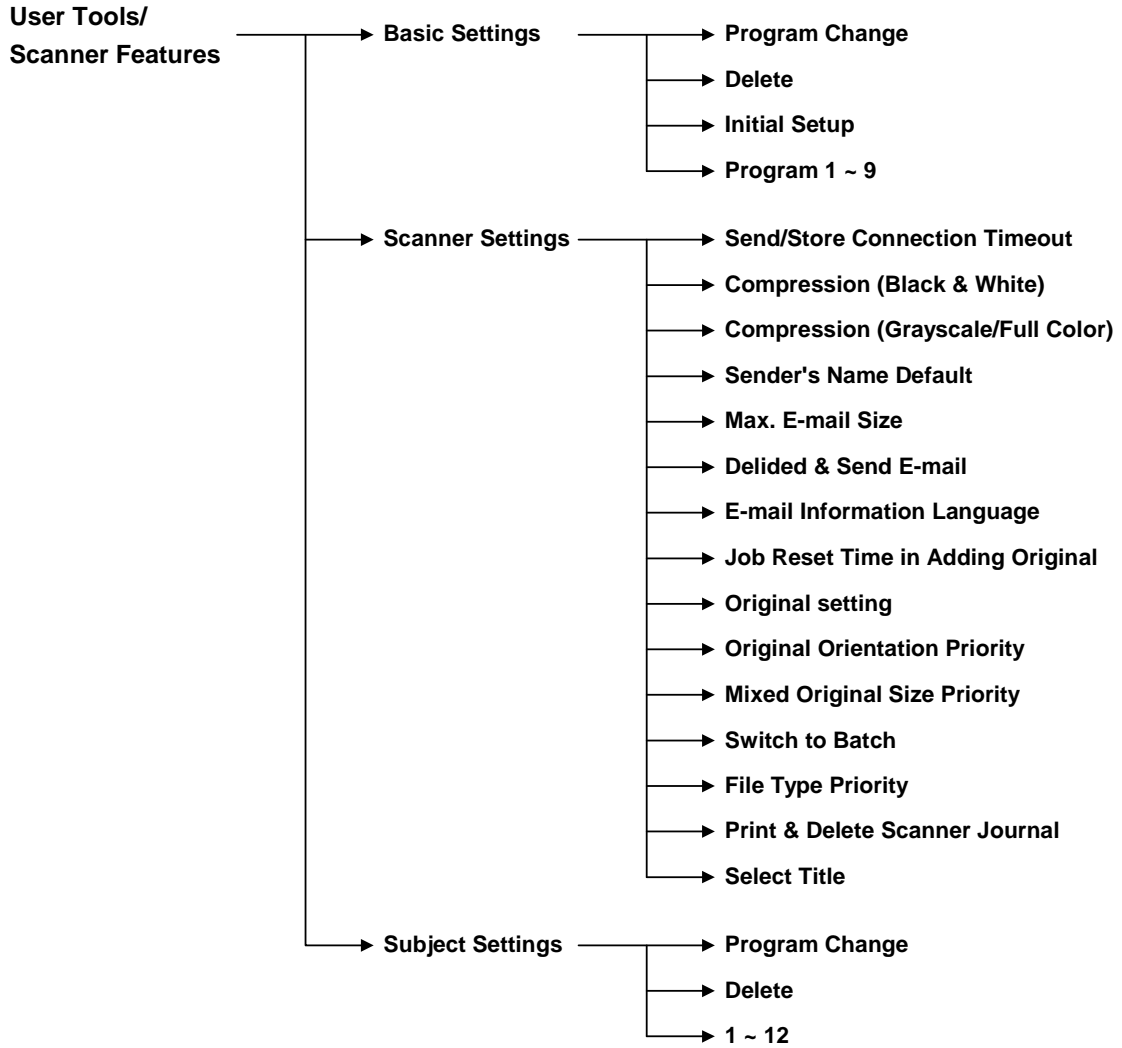

4. DETAILED SECTION DESCRIPTIONS

4.1 OVERVIEW

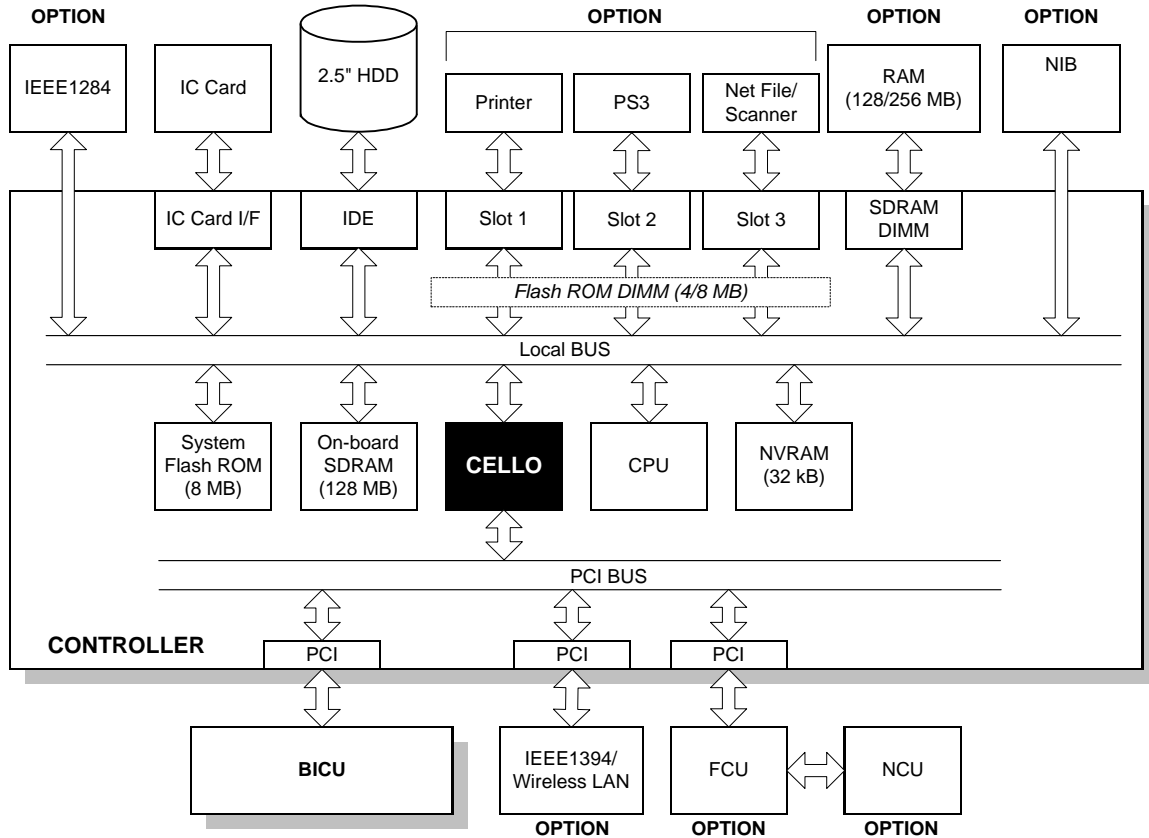

B529D500.WMF

This machine uses the GW architecture, which allows the controller board to control all applications. To enable the application, just install the appropriate ROM DIMM on the controller.

- CPU: PMC RM526A-250
- CELLO: GW architecture ASIC. It controls all the functions of the controller board.
- Flash ROM: 8MB Flash ROM for the system program
- SDRAM (on-board): 128 MB SDRAM, expandable with 128 MB or 256 MB optional DRAM.
- NVRAM: Stores the controller settings
- PCI Interface: Options such as the Fax, IEEE1394, and Wireless LAN are installed. The IEEE1394 and wireless LAN card cannot both be installed at the same time.
- NIB: The NIB is a standard component of the printer and printer/scanner kits. 'Option' in this diagram means that it is an option for the copier (like the printer and printer/scanner kits).
- HDD: Used to store additional soft fonts. Also used for collation, locked print, sample print and form overlay

4.2 PRINT DATA PROCESSING

4.2.1 RPCS DRIVER

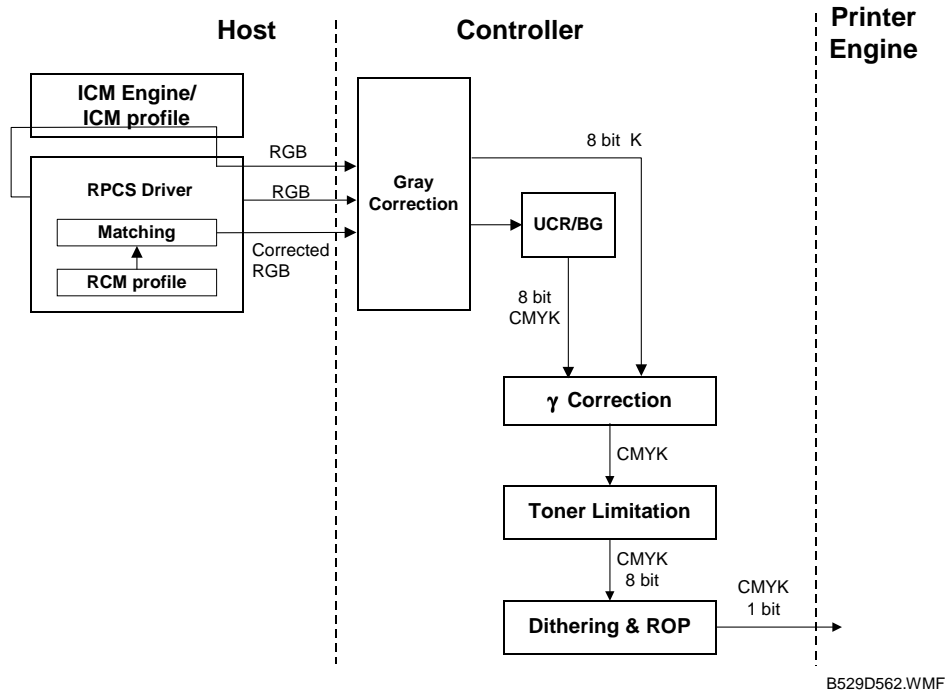

4.2.2 PCL5C DRIVER

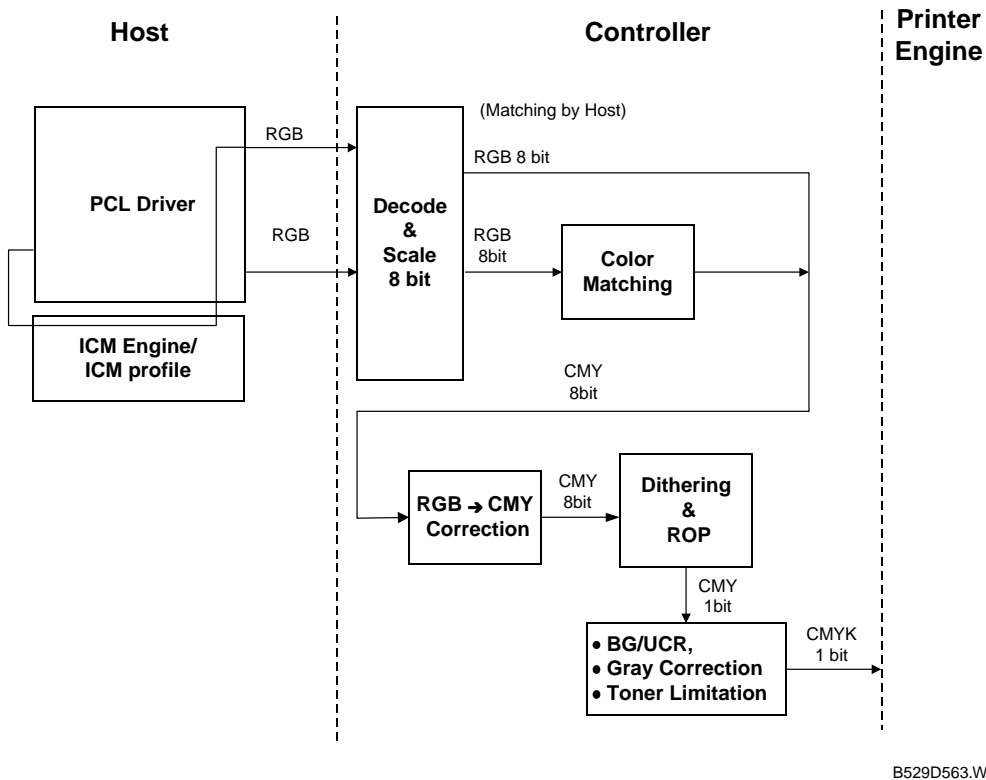

4.2.3 PS3 DRIVER

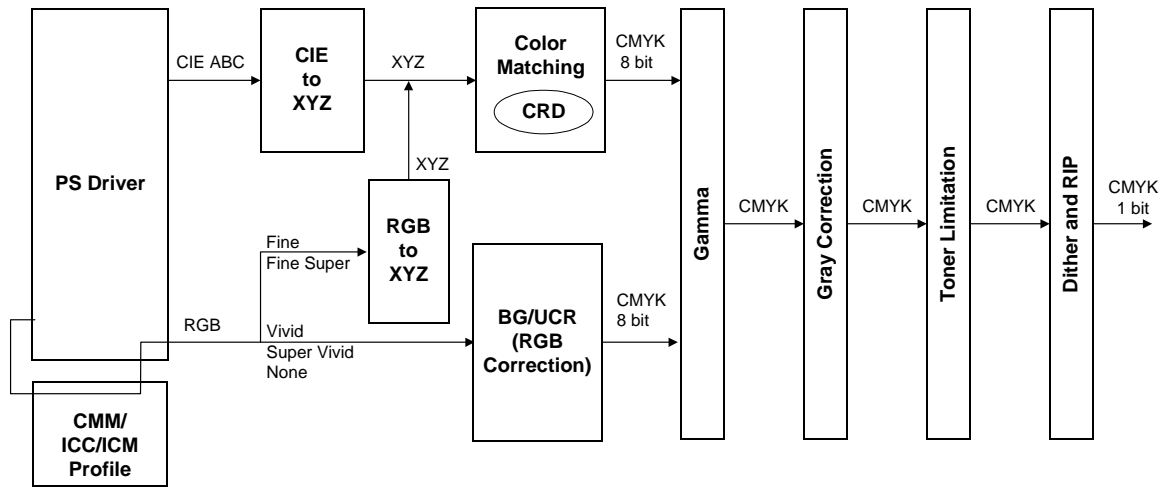

B529D564.WMF

CMS (Color Management System)

CMS optimizes the color print quality using a color profile that is based on the characteristics of the printer. With RPCS, the color profile is applied by the driver. With PS3 and PCL5c, the color profile is applied in the matching/CRD module on the controller except when using CMM/ICC/ICM profiles.

CMS is not used when the color profile setting in the printer driver is set to “Off.”

Gray Correction

Gray correction processes gray with K or CMYK toner depending on the driver settings.

BG/UCR (Black Generation/Under Color Removal)

The RGB data is converted to CMYK data with BG/UCR. During CMYK conversion, some CMY data is replaced with K data by the BG/UCR algorithm.

Gamma Correction

The printer gamma can be adjusted with controller SP mode (Gamma Adj.). For CMYK, there are 15 points between 0 and 100%. The corrected gamma data is stored in NVRAM.

Detailed Descriptions

Toner Limitation

Toner limitation prevents toner from being scattered around text or printed lines.

Maximum values have been prepared independently for text and photo. They can be adjusted with controller SP mode (Toner Limit).

- Default: 180% for text, 250% for photo
- Adjustable range: 100% to 400%

Dither Processing and ROP/RIP

Dither patterns have been prepared for photo and text independently. Dithering converts the 8-bit data to 1-bit data. However, these dither patterns create the illusion of 256 gradations for high quality prints. The optimum dither pattern is selected depending on the selected resolution.

RIP: Raster Image Processing

ROP: Raster Operation

4.3 CONTROLLER FUNCTIONS

4.3.1 SAMPLE PRINT

This function gives users a chance to check the print results before starting a multiple-set print run.

- The size of the hard disk partition for the sample print feature is 5.8 GB. This partition is also used by the collation and locked print features.
- The partition can hold up to 30 files, including files stored using locked print.
- The maximum number of pages is 1,000, including jobs using locked print and collation.

4.3.2 LOCKED PRINT

Using this feature, the print job is stored in the machine but will not be printed until the user inputs an ID at the machine's operation panel. This ID must match the ID that was input with the printer driver.

- Stored data is automatically deleted after it is printed.
- Stored data can be manually deleted at the operation panel.
- The hard disk can hold up to 30 files, including files stored using sample print.
- The maximum number of pages is 1,000, including jobs using sample print and collation.
- Locked print uses the same hard disk partition as sample print and collation, which is 5.8 GB.

4.3.3 JOB SPOOLING

Print data can be spooled (stored) in the machine's HDD, and the machine starts to print when data transfer is complete. Since the machine stores all data first before printing, the host computer is freed up more quickly.

NOTE: 1) The supported print protocols are IPP and LPR.
2) The default setting for this feature is 'off'. The user must switch it on using UP mode to enable this feature.

- The size of the HDD partition for job spooling is 1 GB.
- The partition can hold up to 50 jobs.

Related SP Modes

Job spooling can be turned on and off using printer service mode for each protocol.

"Job spool (LPR)": Job spooling on/off for LPR.

"Job spool (IPP)": Job spooling on/off for IPP.

The machine does not spool jobs when job spooling is switched off with the SP mode, even when the customer switches it on with the user mode.

4.3.4 PAPER SOURCE SELECTION

Tray Priority (Auto Tray Select)

The Tray Priority setting determines the start of the tray search when the user selects “Auto Tray Select” with the driver.

The machine searches for a paper tray with the specified paper size and type.

When no tray contains paper that matches the paper size and type specified by the driver, the controller stops printing until the user loads the correct paper.

The Tray Priority setting can be specified using the Paper Size Setting in the user tools.
(User Tools/ System Settings/ Paper Size Settings)

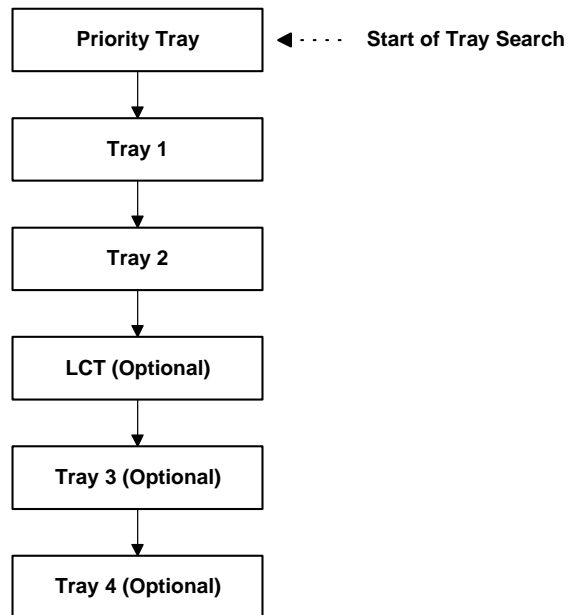

NOTE: The by-pass tray is not part of the tray search.

B529D502.WMF

Tray Lock

If Tray Lock is enabled for a tray, the controller skips the “locked” tray in the tray search process.

The Tray Lock setting can be specified by selecting “No” for the “Apply Auto Paper Select” setting in the Paper Size Setting screen in the user tools.
(User Tools/ System Settings/ Paper Size Settings)

NOTE: The by-pass feeder cannot be locked.

Manual Tray Select

If the selected tray does not have the paper size and type specified by the driver, the controller stops printing until the user loads the correct paper.

4.3.5 AUTO CONTINUE

When this function is disabled, the machine stops printing and cancels the print job if there is no paper tray which matches the paper size and paper type specified by the driver.

If Auto Continue is enabled, the machine waits for a specified period (0, 1, 5, 10, 15 minutes) for the correct size paper to be set in the tray, then cancels the print job if the interval expires.

- The interval can set with the Printer Settings in the user tools.
(User Tools/ Printer Settings/ System/ Auto Continue)

If Auto Continue is disabled, the machine will not print the job, but will not cancel it, so the job stays in the print queue.

If no paper tray matches the paper size and paper type specified by the driver:

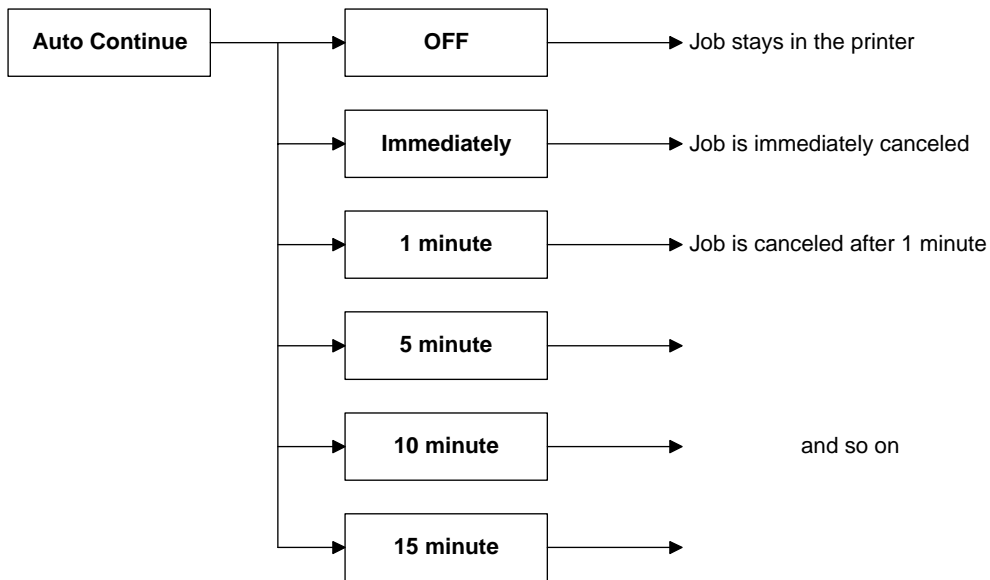

Detailed Descriptions

B529D512.WMF

NOTE: The default setting for Auto Continue is “Off.”

4.3.6 PAPER OUTPUT TRAY

The default paper output tray for each application (copy/fax/printer) can be selected using the System Settings menu in the user tools. (User Tools/ System Settings/ General Features)

If a print job does not specify an output tray or if the driver specifies the default tray, the default paper output tray is used.

Output Tray Selected

- If an output tray is specified by the driver, it overrides the default tray setting in the user tools.
- If the machine cannot print to the selected output tray, it prints to the default paper output tray.
- If the mailbox unit is installed, paper larger than B4 cannot be printed to the standard (internal) tray.
- If paper overflow is detected at the selected output tray, the controller stops printing until the overflow detector goes off.

4.3.7 DUPLEX PRINTING

Duplex printing is not available with all paper sizes. If a job specifies duplex printing but the paper size to be used cannot be used by the duplex unit, the job will be printed single-sided.

- When the by-pass feeder is selected as the paper source, duplex printing is automatically disabled.

4.3.8 STAPLING

Stapling is available when the 500-sheet finisher or 1000-sheet finisher is installed. The finishers have the following stapling positions.

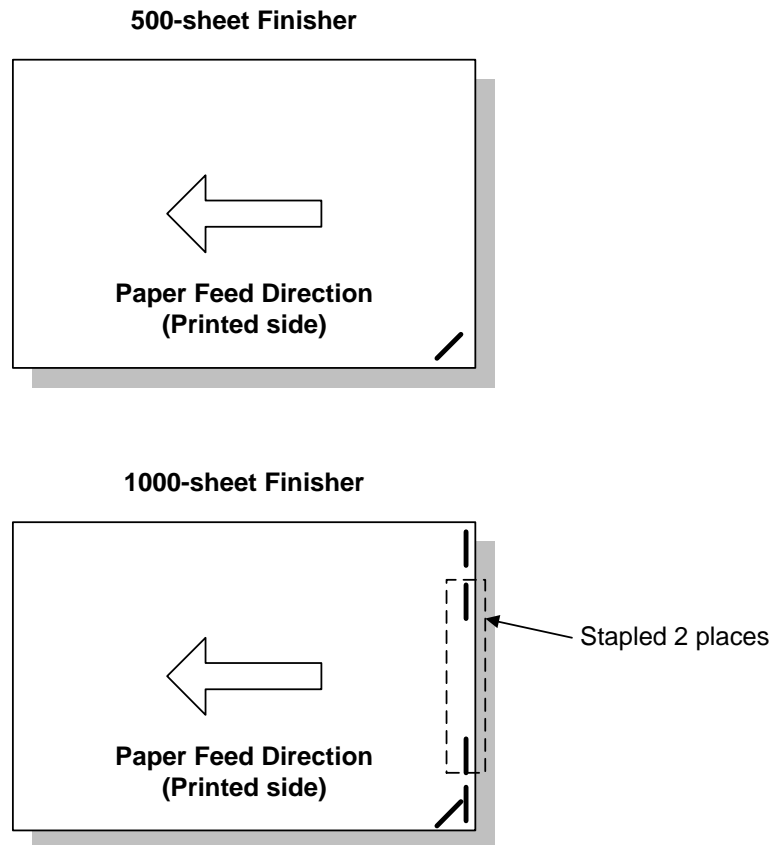

B529D501.WMF

- Depending on the paper orientation, the image may have to be rotated. The controller does the image rotation.
- There is a limit for the number of sheets that can be stapled. If a job has more than this number, it will not be stapled.

4.4 NIB

4.4.1 BLOCK DIAGRAM

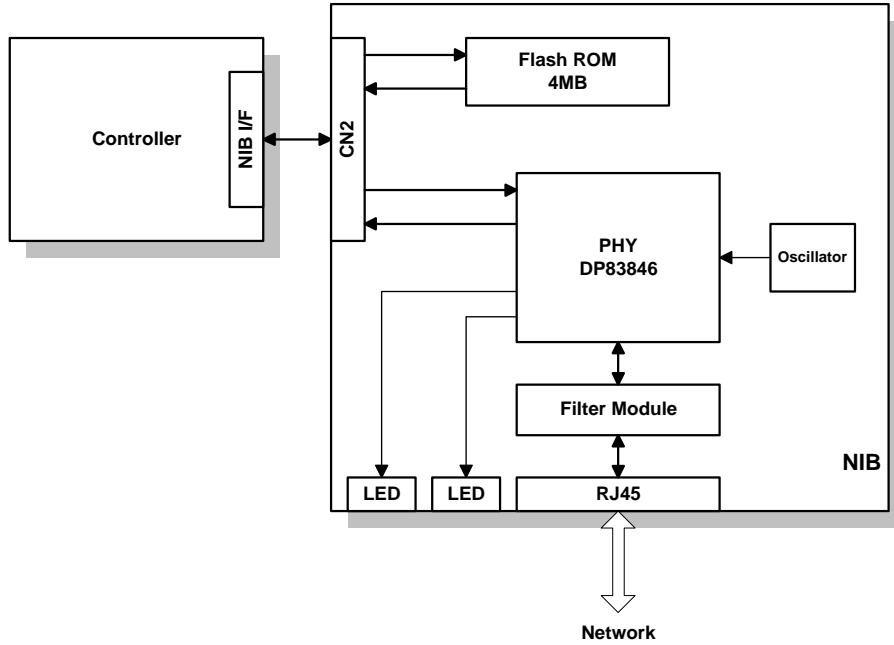

B529D503.WMF

- The Flash ROM contains the NIB firmware. The firmware can be upgraded using an IC card connected to the controller board.

4.4.2 LED INDICATORS

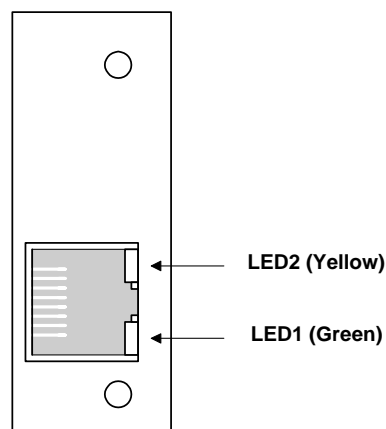

B529D508.WMF

Description	On	Off
LED1 (Green): Link status	Link success	Link failure
LED2 (Yellow): Data rate	100 Mbps	10 Mbps

4.5 IEEE1394 INTERFACE

4.5.1 SPECIFICATIONS

Hardware Specification

Interface: IEEE1394 (6 pins)
 (no power supply, cable power repeated, IEEE1394a-2000 compliant)
 Ports: 2 ports
 Data rates: 400Mbps/200Mbps/100Mbps

System Requirements

PC: Windows PC with IEEE1394 port
 OS: Microsoft Windows 2000 upgraded with service pack 1
 Cable length: 4.5m (15ft)

4.5.2 IEEE1394

IEEE1394, also known as FireWire (a name patented by Apple), is an easy-to-use peer-to-peer networking technology allowing speeds of up to 400 Mbps.

The current standard contains the following features, which are supported in most devices:

- Hot swapping (cables can be connected and disconnected while the computer and other devices are switched on)
- Peer-to-peer networking (no hub required)
- No terminator or device ID is required, unlike SCSI
- Automatic configuration of devices upon start-up, or “plug and play.”
- Real-time data transfer at 100, 200, and 400 Mbps
- Common connectors for different devices

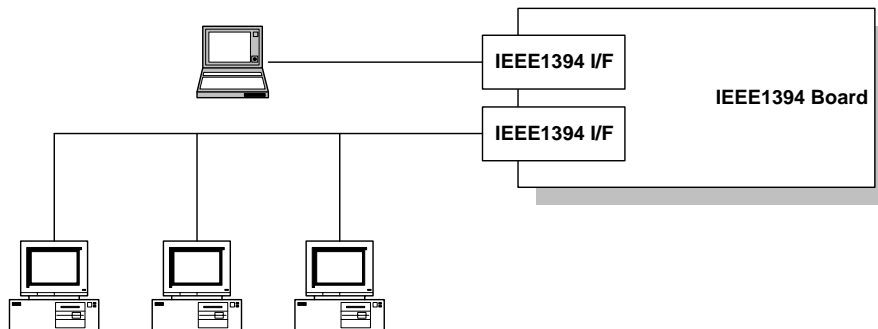

B529D506.WMF

The cable length is limited to 4.5 m (15ft). However, up to 16 cables and 63 devices can be connected to an IEEE1394 network.

IEEE1394 cables can be either 4-pin (data only) or 6-pin (data and power). IEEE1394 allows either 6-pin or 4-pin connectors. However, this machine only uses the 6-pin connectors. The machine has two 6-pin ports.

4.5.3 BLOCK DIAGRAM

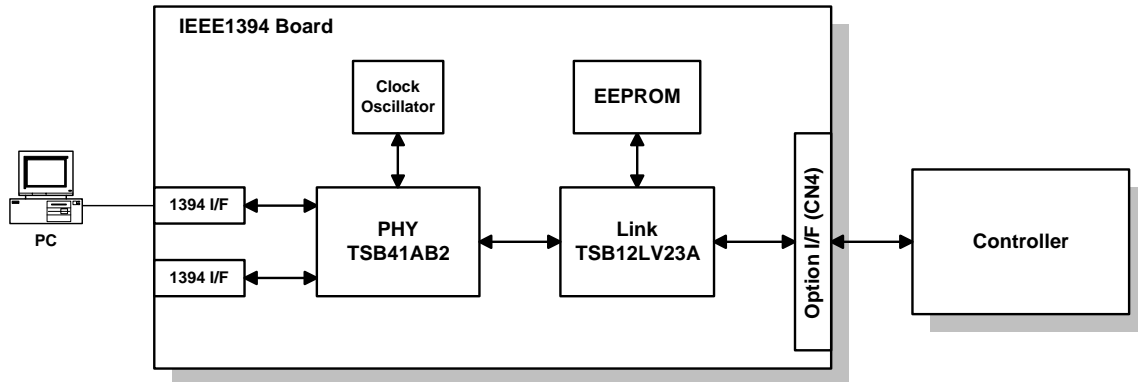

B529D505.WMF

- PHY: Physical layer control device
- Link: Link layer control device
- EEPROM: 256-byte ROM

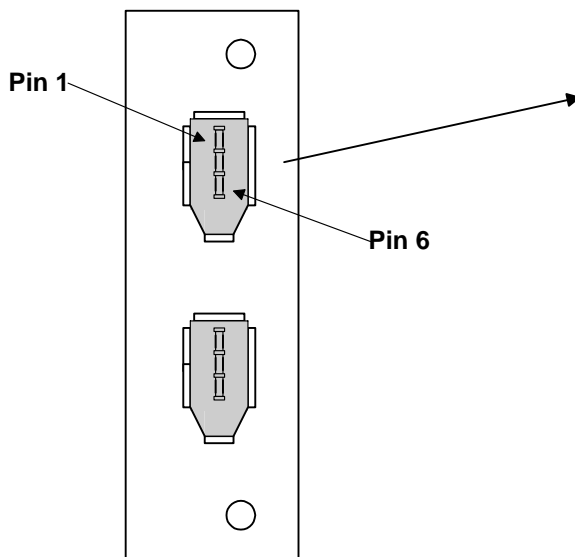

B529D507.WMF

4.5.4 PIN ASSIGNMENT

Pin No.	Signal Description
1	Cable Power
2	GND
3	Receive strobe
4	Transmit data
5	Receive data
6	Transmit strobe

Pin assignment	
Pin 1	Pin 4
Pin 2	Pin 3
Pin 5	Pin 6

4.5.5 REMARKS ABOUT THIS INTERFACE KIT

Note the following points about this unit.

- The machine does not print reports specifically for IEEE1394. Just print the Configuration Page at installation to check that the machine recognizes the card.
- There is no spooler or print queue. If a computer tries to print over the IEEE1394 while the printer is busy, the IEEE1394 interface card inside the printer will return a busy signal.
- After starting a job using IEEE1394, do not switch the printer off until the job has been completed. Even though the printer may appear to be dead, it may be in the middle of an IEEE1394 protocol exchange with the computer.
- When using IEEE1394, it is not possible to check the printer status from the computer with a utility such as Printer Manager for Client.

4.5.6 TROUBLESHOOTING NOTES

If there are problems printing using the IEEE1394 interface, check the following.

- Is the computer using Windows 2000 with service pack 1?
- Has the interface card been replaced recently? Each card has an individual address, similar to the MAC address in an Ethernet card. If the card was changed, the driver cannot find the old card. The new card is another device and a new printer appears in Windows Control panel, and this must be configured in the same way as the printer that was replaced (the old printer icon in Windows Control Panel should be deleted) has to be reconfigured.
- Is there a loop somewhere in the network? An IEEE1394 network must be a chain or a branched chain. There can be no loops.
- Try to find out where in the chain the problem is occurring. Test the machine one-to-one with the computer to determine if the printer is defective (when the printer's interface cable is plugged in, the computer should see 'Printer Ready'; when the cable is disconnected, the computer should see 'Offline').

4.5.7 IP OVER IEEE1394

This machine supports IEEE1394 printing by setting an IP address. This feature is called 'IP over 1394'.

The former IEEE1394 printing without IP address is known as 'SCSI printing'.

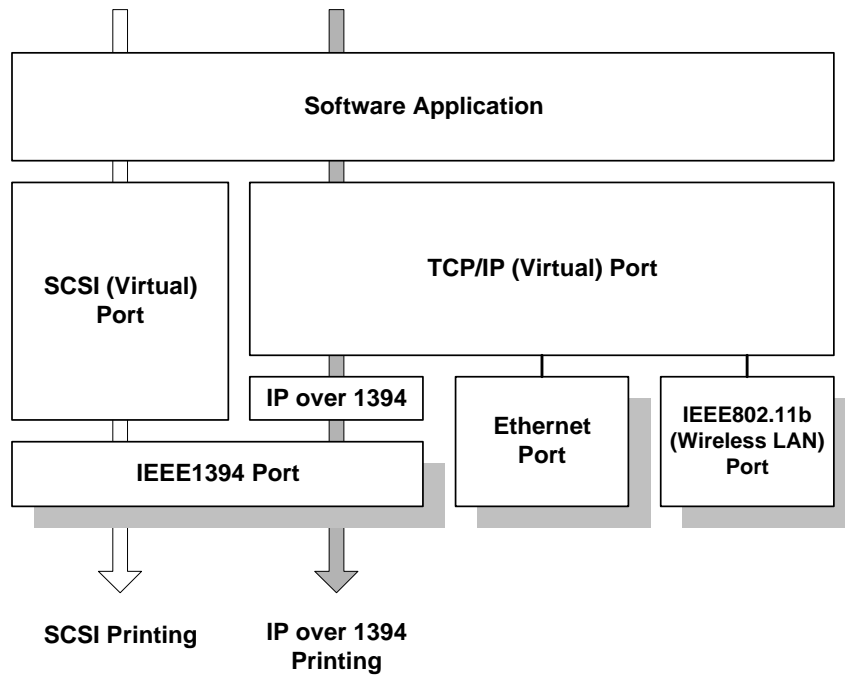

B529D902.WMF

- NOTE:** 1) Windows XP is the only OS which supports IP over 1394.
2) Windows XP and 2000 supports IEEE1394 SCSI printing.

4.6 IEEE802.11B (WIRELESS LAN)

4.6.1 SPECIFICATIONS

A wireless LAN is a flexible data communication system used to extend or replace a wired LAN. Wireless LAN employs radio frequency technology to transmit and receive data over the air and minimize the need for wired connections.

- With wireless LANs, users can access information on a network without looking for a place to plug into the network.
- Network managers can set up or expand networks without installing or moving wires.
- Most wireless LANs can be integrated into existing wired networks. Once installed, the network treats wireless nodes like any other physically wired network component.
- Flexibility and mobility make wireless LANs both effective extensions of and attractive alternatives to wired networks.

Standard applied: IEEE802.11b
 Data transfer rates: 11 Mbps/5.5 Mbps/2 Mbps/1 Mbps (auto sense)
 Network protocols: TCP/IP, Apple Talk, NetBEUI, IPX/SPX
 Bandwidth: 2.4GHz
 (divided over 14 channels, 2400 to 2497 MHz for each channel)

NOTE: The wireless LAN cannot be used together with the Ethernet. The “LAN Type” setting in the Host Interface menu determines the LAN interface to be used.

Detailed Descriptions

4.6.2 BLOCK DIAGRAM

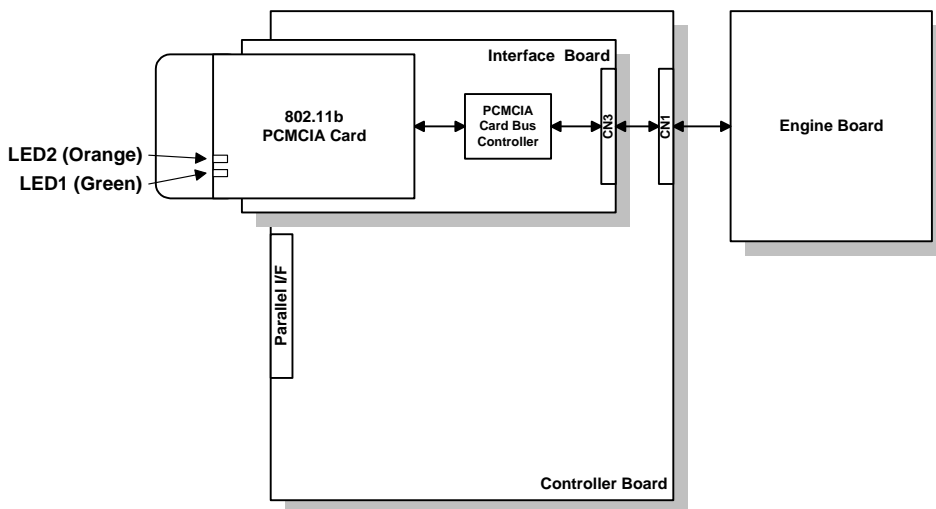

B529D900.WMF

LED Indicators

LED	Description	On	Off
LED1 (Green)	Link status	Link success	Link failure
LED2 (Orange)	Power distribution	Power on	Power off

4.6.3 TRANSMISSION MODE

The following transmission modes are provided for wireless communication.

Ad hoc Mode

The ad hoc mode allows communication between each device (station) in a simple peer-to-peer network. In this mode, all devices must use the same channel to communicate.

In this machine, the default transmission mode is ad hoc mode and the default channel is 11. First, set up the machine in ad hoc mode and program the necessary settings, even if the machine will be used in the infrastructure mode.

To switch between ad hoc and infrastructure modes, use the following user tool: Host Interface Menu - IEEE802.11b - Comm Mode

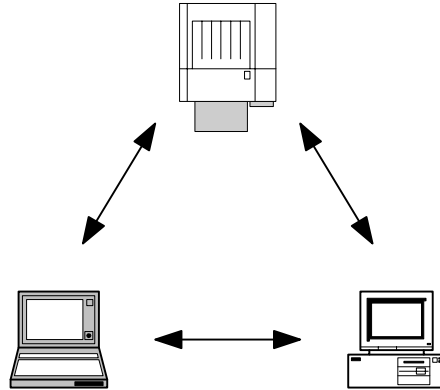

B529D907.WMF

Infrastructure Mode

The infrastructure mode allows communication between each computer and the machine via an access point equipped with an antenna and wired into the network. This arrangement is used in more complex topologies.

- The wireless LAN client must use the same SSID (Service Set ID) as the access point in order to communicate.

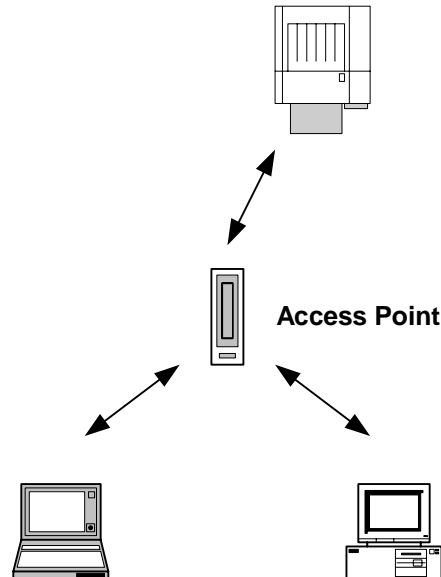

B529D908.WMF

4.6.4 SECURITY FEATURES

SSID (Service Set ID)

The SSID is used by the access point to recognize the client and allow access to the network. Only clients that share the same SSID with the access point can access the network.

NOTE: 1) If the SSID is not set, clients connect to the nearest access point.
2) The SSID can be set using the web status monitor or telnet.

Using the SSID in Ad hoc mode

When the SSID is used in ad hoc mode and nothing is set, the machine automatically uses "ASSID" as the SSID. In such a case, "ASSID" must also be set at the client.

NOTE: SSID in ad hoc mode is sometimes called "Network Name."

WEP (Wired Equivalent Privacy)

WEP is a coding system designed to protect wireless data transmission. In order to unlock encoded data, the same WEP key is required on the receiving side. There is 128 bit WEP keys.

NOTE: The WEP key can be set using the web status monitor or telnet.

MAC Address

When the infrastructure mode is used, access to the network can also be limited at the access points using the MAC address. This setting may not be available with some types of access points.

4.6.5 TROUBLESHOOTING NOTES

Communication Status

Wireless LAN communication status can be checked with the UP mode “W.LAN Signal” in the Maintenance menu. This can also be checked using the Web Status Monitor or Telnet.

The status is described on a simple number scale.

Status Display	Communication Status
Good	76~100
Fair	41~75
Poor	21~40
Unavailable	0~20

NOTE: Communication status can be measured only when the infrastructure mode is being used.

Channel Settings

If a communication error occurs because of electrical noise, interference with other electrical devices, etc., you may have to change the channel settings.

To avoid interference with neighboring channels, it is recommended to change by 3 channels. For example, if there are problems using channel 11 (default), try using channel 8.

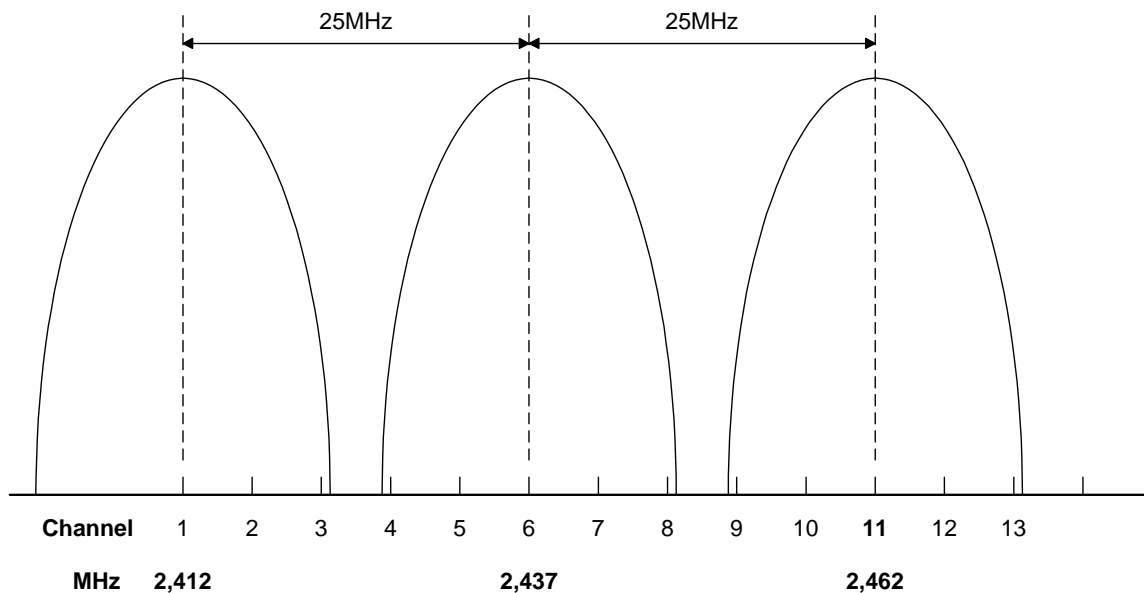

B529D901.WMF

Troubleshooting Steps

If there are problems using the wireless LAN, check the following.

- 1) Check the LED indicator on the wireless LAN card.
- 2) Check if "IEEE802.11b" is selected in the UP mode LAN Type in Network Setup in the Host Interface menu.
- 3) Check if the channel settings are correct.
- 4) Check if the SSID and WEP are correctly set.

If infrastructure mode is being used,

- 1) Check if the MAC address is properly set
- 2) Check the communication status

If the communication status is poor, bring the machine closer to the access point, or check for any obstructions between the machine and the access point.

If the problem cannot be solved, try changing the channel setting.

4.7 SCANNER FUNCTIONS

4.7.1 IMAGE PROCESSING FOR SCANNER MODE

The image processing for scanner mode is done in the IPU chip on the BICU board. The IPU chip chooses the most suitable image processing methods (gamma tables, dither patterns, etc) depending on the settings made in the driver.

The image compression method for binary picture processing can be selected with scanner SP1-004 (either MR, MH, or MMR). For grayscale processing, JPEG is used.

Whether the user selects the image mode using the driver (TWAIN mode) or from the operation panel (Delivery mode), the IPU chip does the image processing using the appropriate image processing methods mentioned above.

Image Data Path

1. Image Store/Image Delivery Mode

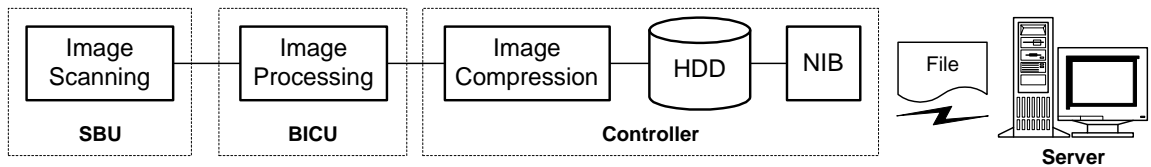

B529D905.WMF

The user can select the following modes from the LCD.

- 1) Delivery only
- 2) Store only
- 3) Store and delivery

After image processing and image compression, all image data for the job are stored in the printer controller HDD using TIFF file format (binary picture processing) or JPEG file format (grayscale processing). The type of TIFF format used depends on the user's scanner settings.

When delivery mode is selected, the controller creates a file which contains the destination and page information, then the controller sends the file to a server.

2. Twain Mode

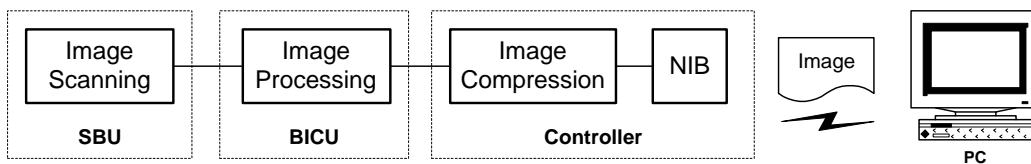

B529D906.WMF

After image processing and image compression, the data (RAW or JPEG) is sent to the scanner Twain driver directory on the computer.

SPECIFICATIONS

1. GENERAL SPECIFICATIONS

1.1 PRINTER

Printing Speed:

	Plain Paper	Thick	OHP
Color	10 ppm	4 ppm	2 ppm
Black & White	36 ppm	6.5 ppm	3.2 ppm

Printer Languages:

PCL5c
 RPCS (Refined Printing Command System)
 PostScript 3 (Option)

Resolution:

600 x 600 dpi (PCL5c/RPCS/PS3)
 300 x 300 dpi (PS3)

Resident Fonts:

PCL:
 35 Intellifonts
 10 True Type fonts
 1 bitmap fonts
 PS3:
 136 fonts (24 Type 2 fonts, 112 Type 14 fonts)

Host Interfaces:

Bi-directional IEEE1284 parallel x 1 (standard)
 Ethernet (100 Base-TX/10 Base-T) (standard)
 IEEE1394 (option)
 IEEE 802.11b (Wireless LAN) (option)

Network Protocols:

TCP/IP, IPX/SPX, NetBEUI, Apple Talk

Memory:

256 MB (Resident 128 MB + 128 MB Memory option)
 384 MB (Resident 128 MB + 256 MB Memory option)

Supported Paper Sizes

Paper Feed

Paper Size			M.U.			B.T.			Dx.	P.T.			LCT		
			NA	ER	AS	NA	ER	AS		Co	NA	ER	AS	NA	ER
A3	SEF	297 x 420 mm	M	A	A	M	A	A	A	A	A	A	-	-	-
B4	SEF	257 x 364 mm	M	A	A	M	M	M	A	M	A	A	-	-	-
A4	SEF	210 x 297 mm	A	A	A	M	A	A	A	M	A	A	-	-	-
A4	LEF	297 x 210 mm	M	A	A	M	M	M	A	A	A	A	M	A	A
B5	SEF	182 x 257 mm	A	A	A	M	M	M	A	M	M	M	-	-	-
B5	LEF	257 x 182 mm	A	A	A	M	M	M	A	M	A	M	-	-	-
A5	SEF	148 x 210 mm	M	M	M	M	A	A	A	M	M	M	-	-	-
A5	LEF	210 x 148 mm	M	A	A	M	M	M	A	M	A	A	-	-	-
B6	SEF	128 x 182 mm	S	S	S	M	M	M	-	-	-	N	-	-	-
B6	LEF	182 x 128 mm	-	-	-	-	-	-	-	-	-	N	-	-	-
A6	SEF	105 x 148 mm	M	M	M	M	M	M	-	-	-	N	-	-	-
A6	LEF	148 x 105 mm	-	-	-	-	-	-	-	-	-	N	-	-	-
DLT	SEF	11" x 17"	A	M	M	A	M	M	A	A	A	A	-	-	-
LG	SEF	8 1/2" x 14"	A	M	M	M	M	M	A	A	M	M	-	-	-
LT	SEF	8 1/2" x 11"	A	A	A	A	M	M	A	A	M	M	-	-	-
LT	LEF	11" x 8 1/2"	A	M	M	M	M	M	A	A	A	A	A	M	M
HLT	SEF	5 1/2" x 8 1/2"	M	M	M	A	M	M	A	M	M	M	-	-	-
HLT	LEF	8 1/2" x 5 1/2"	M	M	M	M	M	M	-	A	M	M	-	-	-
A3 width	SEF	12" x 18"	-	-	-	M	M	M	-	-	-	-	-	-	-
Executive	SEF	7 1/4" x 10 1/2"	M	M	M	M	M	M	A	M	M	M	-	-	-
Executive	LEF	10 1/2" x 7 1/4"	M	M	M	M	M	M	-	-	-	-	-	-	-
F	SEF	8" x 13"	M	M	M	M	A	A	A	M	M	M	-	-	-
Foolscap	SEF	8 1/2" x 13"	M	M	M	M	M	M	A	M	M	M	-	-	-
Folio	SEF	8 1/4" x 13"	M	M	M	M	M	M	A	M	M	M	-	-	-
8 K	SEF	267 x 390 mm	M	M	M	M	M	M	A	M	M	M	-	-	-
16 K	SEF	195 x 267 mm	M	M	M	M	M	M	A	M	M	M	-	-	-
16 K	LEF	267 x 195 mm	M	M	M	M	M	M	A	M	M	M	-	-	-
Custom															
		M.U. (W:100-297, L:148-432mm)	S	S	S	-	-	-	-	-	-	-	-	-	-
		P.T. (W:148-297, L:148-432mm)	-	-	-	-	-	-	-	S	S	S	-	-	-
		B.T. (W:90-305, L:148-457mm)	-	-	-	S	S	S	-	-	-	-	-	-	-
Com10	SEF	4 1/8" x 9 1/2"	-	-	-	S	S	S	-	-	-	-	-	-	-
Monarch	SEF	3 7/8" x 7 1/2"	-	-	-	S	S	S	-	-	-	-	-	-	-
C6	SEF	114 x 162 mm	-	-	-	S	S	S	-	-	-	-	-	-	-
C5	SEF	162 x 229 mm	-	-	-	S	S	S	-	-	-	-	-	-	-
DL Env	SEF	110 x 220 mm	-	-	-	S	S	S	-	-	-	-	-	-	-

M.U.: Main unit **NA :** North America **A :** Automatically processed
Dx. : Duplex **ER :** Europe **M :** Manually selected from operation panel
B.T. : Bypass tray unit **AS :** Asia **S :** Specified from numeric keypad
P.T. : Paper tray unit **Co :** Common **- :** Not supported

NOTE: Envelopes can be fed from the bypass tray. Keep the flap unfolded (if they are not stuck), and let the opposite end be fed first. Duplex printing is not guaranteed.

Paper Output

Paper Size			M.U.	1-B	Shift Tray		500-Sheet Finisher			1000-Sheet Finisher			
					Clr	Shft	Clr	Shft	Stpl	Prf	Clr	Shft	Stpl
A3	SEF	297 x 420 mm	O	O	O	O	O	O ₃₀	O ₃₀	O	O	O	O ₃₀
B4	SEF	257 x 364 mm	O	O	O	O	O	O ₃₀	O ₃₀	O	O	O	O ₃₀
A4	SEF	210 x 297 mm	O	O	O	O	O	O ₃₀	O ₃₀	O	O	O	O ₅₀
A4	LEF	297 x 210 mm	O	O	O	O	O	O ₃₀	O ₃₀	O	O	O	O ₅₀
B5	SEF	182 x 257 mm	O	O	O	O	O	-	-	O	O	O	O ₅₀
B5	LEF	257 x 182 mm	O	O	O	O	O	O ₃₀	O ₃₀	O	O	O	O ₅₀
A5	SEF	148 x 210 mm	O	O	O	O	-	-	-	O	O	O	-
A5	LEF	210 x 148 mm	O	O	O	O	O	-	-	O	O	O	-
B6	SEF	128 x 182 mm	O	O	O	O	-	-	-	O	-	-	-
B6	LEF	182 x 128 mm	-	-	-	-	-	-	-	-	-	-	-
A6	SEF	105 x 148 mm	O	O	O	O	-	-	-	O	-	-	-
A6	LEF	148 x 105 mm	-	-	-	-	-	-	-	-	-	-	-
DLT	SEF	11" x 17"	O	O	O	O	O	O ₃₀	O ₃₀	O	O	O	O ₃₀
LG	SEF	8 1/2" x 14"	O	O	O	O	O	O ₃₀	O ₃₀	O	O	O	O ₃₀
LT	SEF	8 1/2" x 11"	O	O	O	O	O	O ₃₀	O ₃₀	O	O	O	O ₅₀
LT	LEF	11" x 8 1/2"	O	O	O	O	O	O ₃₀	O ₃₀	O	O	O	O ₅₀
HLT	SEF	5 1/2" x 8 1/2"	O	O	O	O	-	-	-	O	O	O	-
HLT	LEF	8 1/2" x 5 1/2"	O	O	O	O	O	-	-	O	O	O	-
A3 width	SEF	12" x 18"	O	-	O	-	-	-	-	O	O	O	O ₃₀
Executive	SEF	7 1/4" x 10 1/2"	O	O	O	O	O	-	-	O	O	O	O ₅₀
Executive	LEF	10 1/2" x 7 1/4"	O	O	O	O	O	-	-	O	O	O	O ₅₀
F	SEF	8" x 13"	O	O	O	O	O	-	-	O	O	O	O ₃₀
Foolscap	SEF	8 1/2" x 13"	O	O	O	O	O	O ₃₀	O ₃₀	O	O	O	O ₃₀
Folio	SEF	8 1/4" x 13"	O	O	O	O	O	-	-	O	O	O	O ₃₀
8 K	SEF	267 x 390 mm	O	O	O	O	O	O ₃₀	O ₃₀	O	O	O	O ₃₀
16 K	SEF	195 x 267 mm	O	O	O	O	O	-	-	O	O	O	O ₅₀
16 K	LEF	267 x 195 mm	O	O	O	O	O	O ₃₀	O ₃₀	O	O	O	O ₅₀
Custom													
M.U. (W:100-297, L:148-432mm)			O	-	O	O	-	-	-	-	-	-	-
P.T. (W:148-297, L:148-432mm)			O	-	O	O	-	-	-	-	-	-	-
B.T. (W:90-305, L:148-457mm)			O	-	O	O	-	-	-	-	-	-	-
Com10	SEF	4 1/8" x 9 1/2"	O	O	O	O	-	-	-	-	-	-	-
Monarch	SEF	3 7/8" x 7 1/2"	O	O	O	O	-	-	-	-	-	-	-
C6	SEF	114 x 162 mm	O	O	O	O	-	-	-	-	-	-	-
C5	SEF	162 x 229 mm	O	O	O	O	-	-	-	-	-	-	-
DL Env	SEF	110 x 220 mm	O	O	O	O	-	-	-	-	-	-	-

Spec.

M.U.: Main unit

1-B : 1-bin paper tray

B.T. : Bypass tray unit

P.T. : Paper tray unit

Clr. : Clear

Shft : Shift

Stpl : Staple

Prf : Proof

O : Output

O₃₀ : Output up to 30 sheets

O₅₀ : Output up to 50 sheets

- : Not output

1.2 SCANNER

Standard Scanner Resolution:	Main scan/Sub scan 600 dpi
Available scanning Resolution Range:	Twain Mode: 100 ~ 1200 dpi Delivery Mode: 100 ~ 600 dpi
Grayscales:	1 bit or 8 bits/pixel each for RGB
Scanning Throughput:	Black & White TWAIN mode: 30 spm Delivery mode: 45 spm (A4L, 200dpi, MMR) Full Color TWAIN mode: 6 spm Delivery mode: 17 spm (A4L, 200dpi, JPEG)
Interface:	Ethernet (100 Base-TX/10 Base-T for TCP/IP)
Compression Method:	MH, MR, MMR (Binary Picture Processing) JPEG (Grayscale Processing)

1.3 SOFTWARE ACCESSORIES

The printer/scanner drivers and utility software are provided on one CD-ROM. An auto-run installer allows you to select which components to install.

Printer Drivers

Printer Language	Windows 95/98/ME	Windows NT4.0	Windows 2000	Windows XP	Macintosh
PCL 5c	Yes	Yes	Yes	Yes	No
PS3	Yes	Yes	Yes	Yes	Yes
RPCS	Yes	Yes	Yes	Yes	No

- NOTE:**
- 1) The printer drivers for Windows NT 4.0 are only for the Intel x86 platform. There is no Windows NT 4.0 printer driver for the PowerPC, Alpha, or MIPS platforms.
 - 2) The PS3 drivers are all genuine AdobePS drivers, except for Windows 2000/XP, which uses Microsoft PS. A PPD file for each operating system is provided with the driver.
 - 3) The PS3 driver for Macintosh supports Mac OS 9.2.1 (Max OS X: PDD Installer).
 - 4) The following Unix versions are supported:
TBA

Printer Utility Software

Software	Description
Agfa Monotype Font Manager (Win 95/98/M3, NT4, W2000)	A font management utility with screen fonts for the printer.
SmartNetMonitor for Admin (Win 95/98/M3, NT4, W2000)	A printer management utility for network administrators. NIB setup utilities are also available.
SmartNetMonitor for Client (Win 95/98/M3, NT4, W2000)	A printer management utility for client users.
Printer Utility for Mac (Mac OS 9.x)	This software provides several convenient functions for printing from Macintosh clients.
1394 Utility (Win 2000/XP)	A utility for removal IEEE 1394 printers.
LAN-FAX M2 (Win 95/98/ME, NT4, 2000/XP)	PC LAN FAX driver
Address Book (Win 95/98/ME, NT4, 2000/XP)	A utility for PC LAN Fax.
DeskTopBinder V2 Lite (Win 95/98/ME, NT4, 2000/XP)	A utility for document management

Spec.

Scanner Driver

- Network Twain Driver for Win95/98/ME/NT3.51/NT4.0/2000/XP

Scanner Utilities

- Scan Router V2 Lite (Cherry-Lite) for Win95/98/ME/NT4.0/2000/XP
- Desk Top Binder V2 Lite (Plumeria-Lite) for Win95/98/ME/NT4.0/2000/XP